

**Corema**  
GELATO EQUIPMENT  
by **TELME**

**THERMOGEL 3-6**  
**THERMOGEL 4-8**

*Food processor*

**OPERATING INSTRUCTIONS**

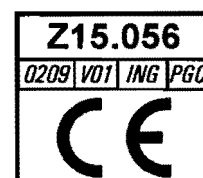

Dear customer,

we congratulate you for choosing a high quality product  
which will surely satisfy your expectations.

With our thanks for choosing us,  
we kindly invite you to examine the present operating instructions manual  
before operating your new machine.

## SUMMARY

<b>1</b>	<b>IMPORTANT SAFETY MEASURES</b> .....	<b>4</b>	<b>7</b>	<b>USING THE EQUIPMENT</b> .....	<b>14</b>
1.1	Technical documentation .....	4	7.1	Warnings .....	14
1.2	Accident prevention .....	4	7.2	Controls and info / warning lights .....	14
1.3	Damage prevention .....	5			
<b>2</b>	<b>SAFETY DEVICES</b> .....	<b>6</b>	<b>8</b>	<b>PROGRAM SETTINGS</b> .....	<b>16</b>
2.1	Extraction door protections .....	6	8.1	Language selection and Key to symbols .....	16
2.2	Extraction door's grill .....	7	8.2	LCD Adjustment .....	17
2.3	Lid's magnetic sensor .....	7	8.3	General data - more .....	18
2.4	Lid's grill .....	7	8.4	Working parameters .....	19
			8.5	Programme structure .....	21
<b>3</b>	<b>MACHINE'S MAIN PARTS</b> .....	<b>8</b>	8.6	Program from 1 to 5 (preset) .....	22
			8.7	Saving free programmes (from 6 to 24) .....	23
<b>4</b>	<b>TECHNICAL DATA</b> .....	<b>9</b>	<b>9</b>	<b>PREPARING MACHINE FOR PRODUCTION AND GENERAL INFORMATION</b> .....	<b>24</b>
4.1	Technical data and CE mark plate .....	9			
4.2	Acoustic pressure .....	9	<b>10</b>	<b>WASHING AND SANITATION</b> .....	<b>25</b>
<b>5</b>	<b>MOVING AND UNPACKING</b> .....	<b>9</b>	10.1	Rinse - preliminary wash .....	25
5.1	Moving machine in its packaging .....	9	10.2	Parts disassembling .....	25
5.2	Unpacking .....	10	10.3	Washing .....	26
<b>6</b>	<b>INSTALLING</b> .....	<b>10</b>	10.4	Parts reassembling .....	27
6.1	Placing your machine .....	10	10.5	Sanitation .....	28
6.2	Assembling .....	11	<b>11</b>	<b>MAINTENANCE</b> .....	<b>28</b>
6.3	Connecting to power .....	11	11.1	Standard maintenance (operator) .....	28
6.4	Connecting to water supply (water condensing machines) .....	12	11.2	Check of safety devices .....	30
6.5	Checking rotation .....	13	11.3	Yearly maintenance .....	30
			<b>12</b>	<b>PERIODS OF INACTIVITY</b> .....	<b>30</b>
			<b>13</b>	<b>MALFUNCTIONS</b> .....	<b>31</b>

### WARNING:



**GENERAL/MECHANICAL  
DANGER**



**DANGEROUS  
VOLTAGE**



**DANGEROUS  
TEMPERATURE**

A TEXT IN CAPITOL LETTERS, IDENTIFIED BY ONE OF THE SYMBOLS ABOVE, CONTAINS INSTRUCTIONS THAT, IF NOT FOLLOWED, MAY CAUSE HARM TO PEOPLE.



A text in lower-case, identified by this symbol, contains instructions that, if not followed, could cause damages or malfunctions to the device, or falls in its quality.

# 1 IMPORTANT SAFETY MEASURES



PLEASE READ THESE INSTRUCTIONS BEFORE ATTEMPTING TO INSTALL AND OPERATE YOUR MACHINE.



THIS MANUAL PROVIDES ALL INFORMATION REQUIRED TO INSTALL, OPERATE AND MAINTAIN MACHINE UNDER SAFE CONDITIONS. FAILURE TO COMPLY WITH THE SAFETY MEASURES SET OUT IN THIS HANDBOOK MAY RESULT IN SERIOUS DAMAGE TO THE MACHINE AS WELL AS FORFEIT ANY MANUFACTURER'S GUARANTEE.

## 1.1 Technical documentation

- All technical documentation supplied with the FOOD PROCESSOR (from now on referred to as "MACHINE") is an INTEGRAL PART of the machine and therefore must be kept in a safe place for all the duration of the machine's life. This documentation, in compliance with the law in force (EU directives on health and safety measures), includes:
  - OPERATING INSTRUCTIONS (this manual): it must be read by the USER as well as anyone authorized to INSTALL it. It provides all information required to correctly install the machine, correctly operate it, for routine maintenance and any possible malfunction of the machine;
  - TECHNICAL HANDBOOK: it contains the machine's technical specifications (characteristics, diagrams, spare parts etc.) It is to be referred to by the AUTHORIZED ASSISTANCE SERVICE personnel to whom any call for assistance must be given.
  - EU DECLARATION OF COMPLIANCE: in compliance with EU directives relevant to the machine;
  - FORM of electric running tests.
- In case of sale or transfer of the machine to another person, the above documentation must be handed over to the new owner in order to become acquainted with all safety norms, technical specifications as well as how to operate the machine.

## 1.2 Accident prevention



ALWAYS FOLLOW THESE SAFETY MEASURES TO PREVENT PERSONAL INJURIES!

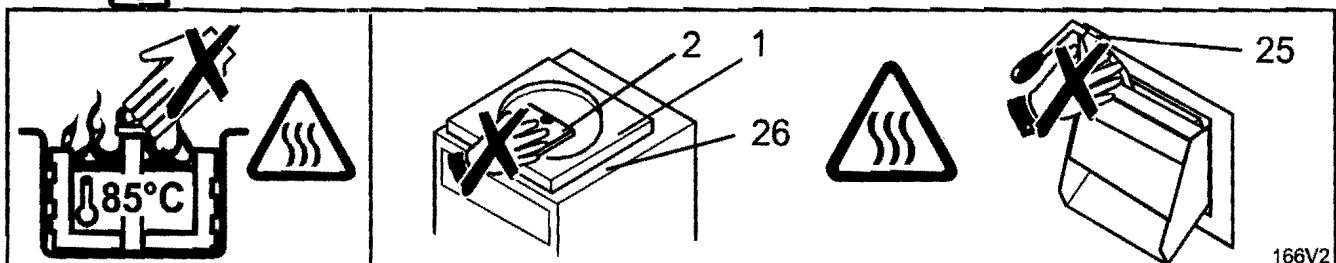

**RESIDUAL HAZARD:** DURING HEATING PHASE THE PRODUCT IS BROUGHT TO HIGH TEMPERATURES. IN SUCH CONDITIONS CONTACT WITH THE PRODUCT, WITH THE LID [1], WITH THE GRID COVER [2], WITH THE EXTRACTION HATCH [25] OR WITH THE UPPER SURFACE [26] CAN CAUSE SERIOUS BURNS.

- Always check that heating/cooling cycle is completed or that the product's temperature, as shown on the display, is sufficiently low before opening the lid or the extraction door;
- Beware in case of a power supply failure during operation. The product's temperature inside the tub may be high and it is not shown on the machine's display;

*Note:* In case of an electrical power supply failure during operation, when power is back on, the machine will automatically start from the beginning of the cycle. Should power stop at the end of the cycle, when the final preservation phase has started, the machine will pause on preservation phase.

- If in doubt whether the product's temperature is sufficiently low, do not open the lid or the extraction door, unless it is absolutely necessary. Should this occur, wear protective clothing (gloves, overalls, etc.) in order to avoid direct contact with the product.
- Do not insert your fingers or any objects through the machine's grills, loopholes or drain holes.
- Do NOT remove or hide, for any reason, any label applied to the machine.
- NEVER open protective panels. There are no internal parts in the machine which can be operated by the user.
- The user MUST NOT carry out any operations not specified in this manual or requiring tools not supplied with the machine by the manufacturer. These must be exclusively carried out by Service Assistance personnel.
- Always unplug machine before undertaking any operation requiring access to the machine's moving parts.
- Any modification to the electrical circuit must be exclusively carried out by qualified and certified personnel.
- The machine is designed to be operated by adults: do not allow children to get close and untrained people to operate it.
- Modifying or attempting to modify the machine could be dangerous as well as forfeit any manufacturer's guarantee.



**OPERATING THE MACHINE, AS ANY OTHER ELECTRICAL EQUIPMENT, ENTAILS OBSERVING SOME VERY IMPORTANT SAFETY RULES, IN PARTICULAR:**

- Do not touch it with wet or damp feet or hands.
- Do not operate when barefoot.
- Do not pull electrical feeding cable to unplug.
- Do not expose machine to rain and prevent any water from entering, i.e. during washing.
- In case of failure and/or malfunction and any time there is apparent damage to the cable, cut power off and call Assistance Service.

### 1.3 *Damage prevention*



**ALWAYS comply with the following norms to avoid DAMAGES to the machine and/or ALTERING the quality of the product.**

- Any use of the machine other than mixing and whipping with heat treatments, cooling and heating mixtures and food is to be considered improper.
- Do not operate machine in dry conditions.
- Do not drop or knock any of the machine's parts.
- Only use original spare parts.
- BEFORE starting production check that all settings are suitable to the type of production, in particular HEATING PRESERVATION TIME which is shown in MINUTES.
- If you are not going to use the machine for a prolonged period of time, or for ever, proceed as explained in Chapter 10 - Periods of inactivity.

## 2 SAFETY DEVICES



**DO NOT TAMPER WITH SAFETY DEVICES.**



**REGULARLY CHECK SAFETY DEVICES (PAR. 9.2) AND DO NOT USE MACHINE WHEN SAFETY DEVICES ARE DAMAGED OR NOT WORKING.**



**THE MANUFACTURER IS NOT RESPONSIBLE FOR POSSIBLE DAMAGES CAUSED TO PEOPLE OR OBJECTS BY THE ALTERING OR BYPASSING SUCH DEVICES OR RELATIVE CIRCUITS.**



**IN CONFORMITY WITH NORM EN 294 06/1992 AND ENSUING MODIFICATIONS, THE MACHINE IS SUPPLIED WITH APPROVED SAFETY DEVICES, DESIGNED FOR THE USE OF PERSONS OVER THE AGE OF 14 AND IN COMPLIANCE WITH ALL THE SAFETY NORMS IN FORCE (SEE ALSO PAR. 1.2).**

### 2.1 Extraction door protections

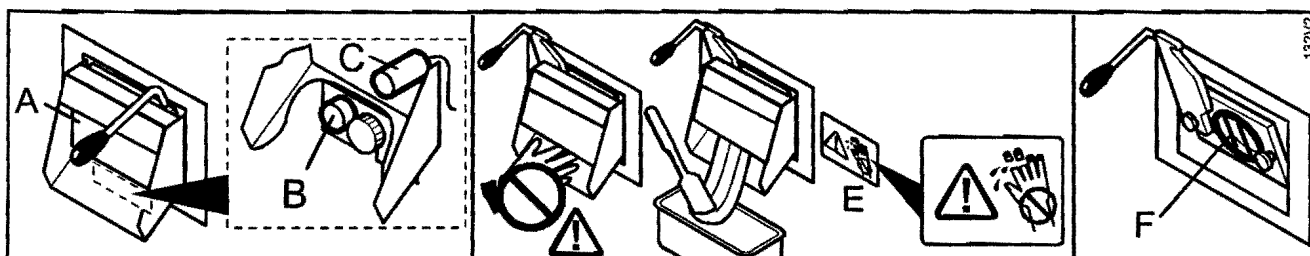

The extraction door chute has a tilting protection flap [A]. The product during extraction lifts this. The flap together with the fixed grill [F] prevents fingers or objects from being **ACCIDENTALLY** inserted through the extraction door.

In order to ensure a regular operation no protection was possible as to prevent fingers and objects from being **VOLUNTARILY** inserted through the extraction door (according to **Machines Directives 89/392/CEE and ensuing modifications, appendix I, Art. 1.1.2.b, 3<sup>rd</sup> paragraph**). Due to its thickness and small pieces of dried or fresh fruit, the finished product must be completely extracted through a short, wide and unobstructed aperture.



**INELIMINABLE HAZARD: WHEN THE MACHINE IS OPERATING YOU MUST NOT MANUALLY RAISE THE PROTECTION COVER [A]; YOU MUST NOT UNDER ANY CIRCUMSTANCES WHATSOEVER INSERT HANDS OR OBJECTS THROUGH THE FIXED GRID [F] OR THE HATCH. IF THIS ADVICE IS NOT ADHERED TO THE OUTCOME COULD BE FINGER AMPUTATION (THE BEATER/MIXER PASSES VERY CLOSE TO THE HATCH) OR SERIOUS DAMAGE TO THE MACHINE (WHERE OBJECTS ARE USED).**

*Note:* The machine will not operate without the protection flap since the flap includes a safety magnetic contact [C] and its magnet [B] (**89/392/CEE and ensuing modifications, Appendix 1, Art. 1.1.2.b, 2<sup>nd</sup> paragraph**).



**THE MAGNETS AND THEIR CONTACTS ARE IMPORTANT SAFETY DEVICES!**

The user is warned of the above **INELIMINABLE HAZARD** (**89/392/CEE and ensuing modifications, Appendix I, Art. 1.1.2.b, 3<sup>rd</sup> paragraph and 1.7.2**) by a plate [E] affixed next to the extraction chute, which is in position even when no protection flap is installed.

## 2.2 Extraction door's grill

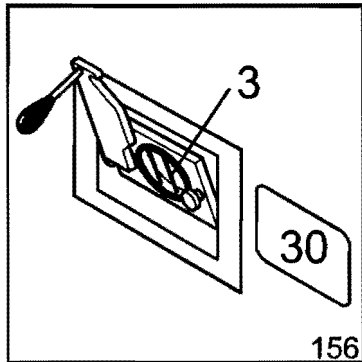

In some models, a fixed protection grill [3] prevents fingers or objects from being ACCIDENTALLY caught inside the extraction chute. In order to insure normal operation it is not possible to adjust the fixed grill as to prevent fingers and objects from being VOLUNTARILY inserted through the extraction chute (according to Machines Directive 89/392/CEE and ensuing modifications, Appendix I, Art. 1.1.2.b, 3<sup>rd</sup> paragraph).



**RESIDUAL HAZARD: DO NOT FOR ANY REASON INSERT FINGERS OR OBJECTS THROUGH THE GRILL OF THE EXTRACTION DOOR WHEN THE DEVICE IS IN FUNCTION.**

The user is warned of the above residual hazard (89/392/CEE and ensuing modifications, Appendix. 1, Art. 1.1.2.b, 3<sup>rd</sup> paragraph and 1.7.2) by a plate [30] affixed next to the extraction chute.



**DO NOT HANDLE OR REMOVE THE GRILL [3] FROM ITS SETTING IN THE EXTRACTION DOOR!**

## 2.3 Lid's magnetic sensor

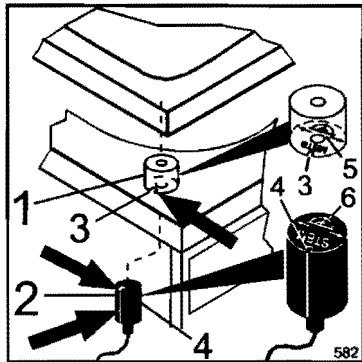

This safety device, featuring an approved type magnet [1] and a magnetic contact [2] avoids accidents caused by the accidental starting of the beater when the lid is open. In consequence the device can't operate when the lid is open, and if it is opened during its functioning the beater immediately stops.

In any case the lid's magnetic sensor MUST NOT be considered a control to be used for the normal stop of the device.



**DURING THE NORMAL USE, THE DEVICE MUST BE STOPPED ONLY BY USING THE BUTTONS ON THE CONTROL KEYPAD, AND NOT BY OPENING THE LID.**

The magnet [1] and the magnetic contact [2] MUST be assembled as follows: the grooves [3] and the stencilled semicircle [5] on the bottom of the magnet [1] must coincide with the grooves [4] (marked by a white line down the side) and the stencilled semicircle [6] on top of the magnetic contact [2]. The device will not work unless all parts have been correctly assembled in accordance with these instructions.

## 2.4 Lid's grill

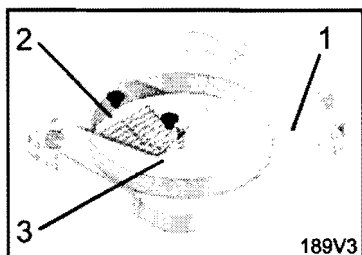

The tub's lid [1] has a rectangular opening, a integrated safety grill [3] and a small lid [2] to allow ingredients to be added to the mixture in the tub without opening the lid (thus avoiding stopping machine). A integrated grill [3], whose dimensions comply with industrial injury legislation in force, prevents fingers from touching the rotating beater.



**DO NOT TAMPER WITH NOR REMOVE THE GRILL [3] FROM THE LID [1].**



**Do not insert any OBJECTS through the grill when machine is functioning.**



**WARNING: DURING HEATING CYCLE THE PRODUCT IS BROUGHT TO HIGH TEMPERATURES. TO AVOID SERIOUS BURNS PROTECTIVE GLOVES MUST BE WORN BEFORE TOUCHING THE LID [1], THE GRID COVER [2] OR THE GRID ITSELF [3].**

### 3 MACHINE'S MAIN PARTS

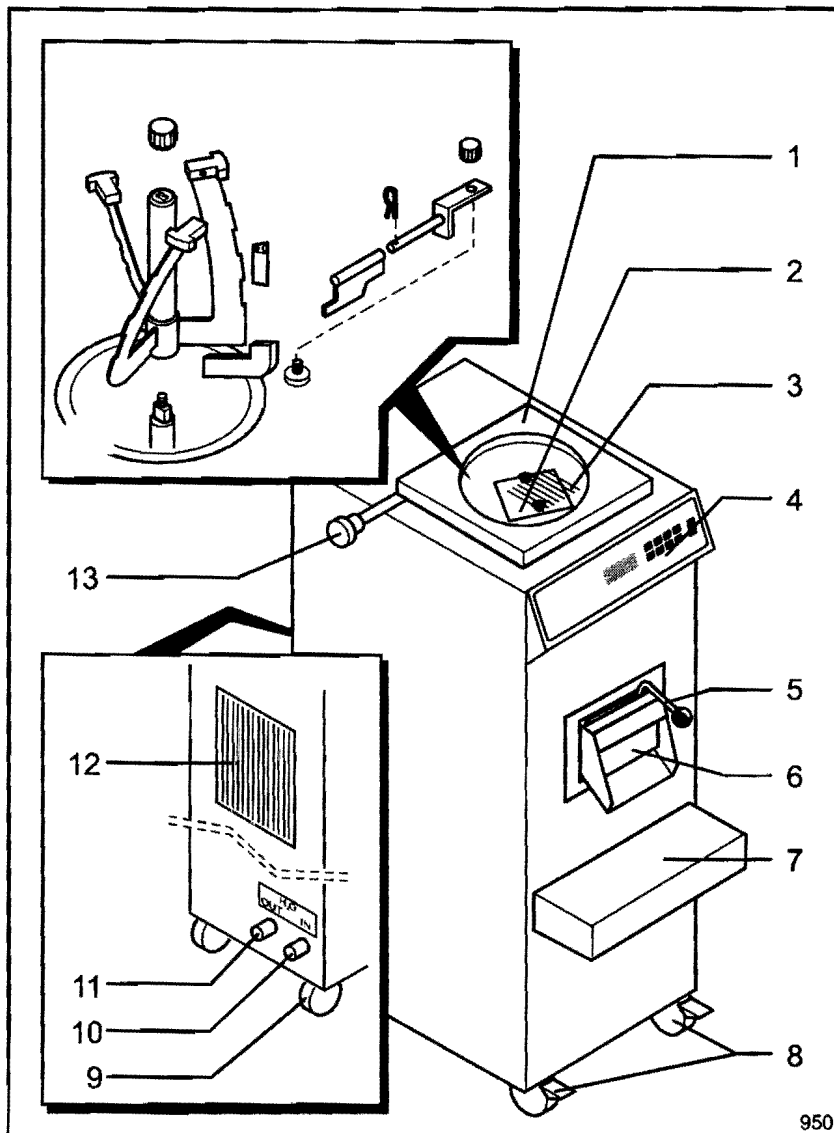

- 1 Tub's lid
- 2 Small lid
- 3 Lid's integrated grill
- 4 Control panel
- 5 Extraction door lever
- 6 Extraction door chute and protection flap
- 7 Basin support
- 8 Front castors (with brakes)
- 9 Rear castors (without brakes)
- 10 Condensation water INLET \*
- 11 Condensation water OUTLET \*
- 12 Air condensing grill \*\*
- 13 Lid's hinge pin
- 14 Tub
- 15 Beater
- 16 Beater's fixing knob °°
- 17 Fixed centering runners \*\*\*
- 18 Side scrapers
- 19 Bottom scraper
- 20 Movable blade
- 21 Safety peg
- 22 Movable blade support
- 23 Movable blade fixing knob °°

Note: \* = Present on machines with Air condensing system only; \*\* = Present on machine with Water condensing system only; \*\*\* = Present on model 4-8 only; °° = On model 3-6 only, knobs 16 and 23 are exactly the same and therefore interchangeable.

## 4 TECHNICAL DATA

### 4.1 Technical data and CE mark plate.

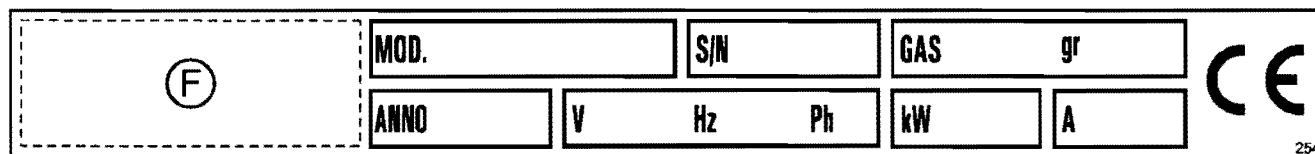

The technical data and CE mark plate must not be removed. It is positioned on the machine's rear side and shows:

- manufacturer's name and address [F];
- model's denomination [MOD] and serial number [S/N];
- types [GAS] and quantities [gr] of refrigerating gases included;
- year of manufacturing [ANNO];
- tension [V], frequency [Hz] and number of phases [Ph], electrical input power [kW] and current [A];
- CE mark.

### 4.2 Acoustic pressure

The continuous acoustic pressure level measured in your machine is indicated in the Technical Handbook (Par. Technical Data). All measurements have been taken while the machine was operating, 1 m from the machine and 1.60 m from ground level.

## 5 MOVING AND UNPACKING



Keep machine in an upright position **AT ALL TIMES** to obtain optimal working conditions, both during transport and installation and use. Keep to instructions on the box.

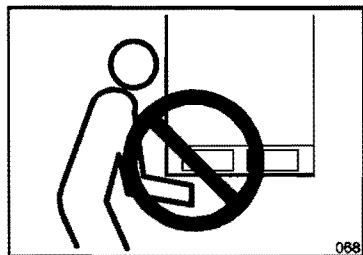

*Note:* it is advisable to have all moving, unpacking and installation operations carried out by our Assistance Service or by authorized personnel supplied with suitable tools.



**USE SUITABLE LIFTING EQUIPMENT TO LIFT MACHINE. IT IS DANGEROUS TO ATTEMPT TO LIFT MACHINE BY HAND.**

Net and gross weight specifications are quoted on the packaging and in the documents supplied.

### 5.1 Moving machine in its packaging

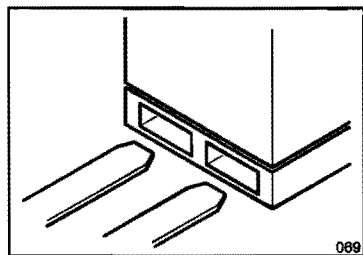

The packaging is designed to provide maximum protection from knocks and external agents.

Therefore it is advisable to carry the packed machine as close as possible to the site where it will be installed.

To move the packaged machine use a lift-fork truck or a bench trolley, and insert forks in the openings in the base.

## 5.2 Unpacking

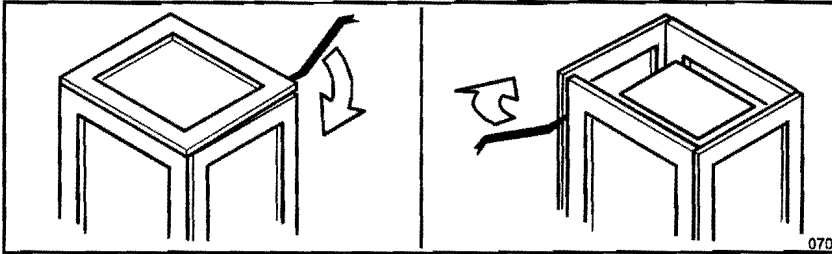

- Remove nails from top panel and remove side panels;
- remove packaging and check that machine is intact. If in doubt, do not use it and ask your Dealer.



**ONLY THE AUTHORIZED ASSISTANCE SERVICE IS ALLOWED TO REMOVE THE SIDE PANELS, FOLLOWING THE INSTRUCTIONS BELOW. DO NOT DAMAGE ANY INSIDE PARTS.**

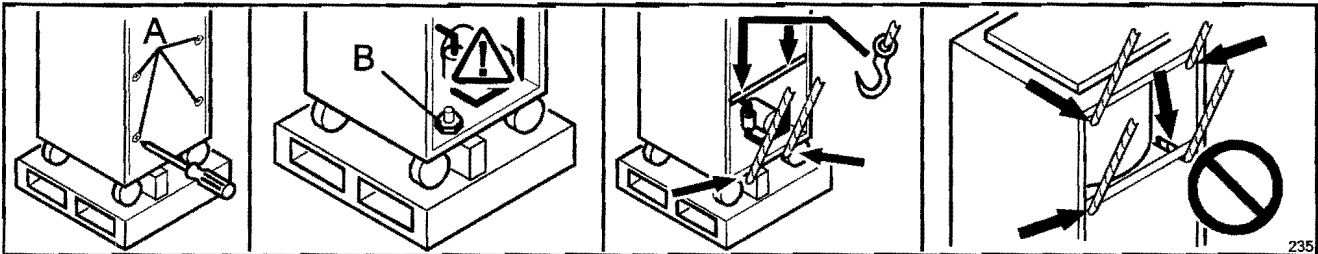

- unscrew fixing screws [A] and remove both side panels;
- unscrew bolts [B] fixing the machine's frame to the packaging's base;



**The supply cable's outlet is on the machine's bottom side. Do not damage when lifting machine.**

- lift machine from base pulling upwards from the frame's carrying parts. Remove base and gently lower machine onto the ground.



**Do not put any object, rods or brackets THROUGH the machine as this could cause damage to the machine's inside parts.**

- close side panels;
- dispose of recyclable (♻️) packaging.

## 6 INSTALLING



**INSTALLATION MUST BE CARRIED OUT EXCLUSIVELY BY CERTIFIED AND AUTHORIZED TECHNICIANS, AND ACCORDING TO THE NORMS CURRENTLY IN FORCE AND FOLLOWING THE INSTRUCTIONS BELOW.**

### 6.1 Placing your machine

Place the machine on the floor, on a flat and steady surface.

Place machine away from sources of heat, avoiding direct exposure to sunlight and allowing air to circulate around it.

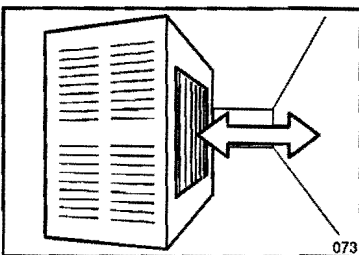

Stop front wheels brake.



**Machines supplied with an AIR CONDENSING system need at least 50 cm room in front of the condenser grill to allow the refrigerator to correctly function. The machine's detailed dimensions are included in the Technical handbook (Par. Technical Data).**

## 6.2 Assembling

Some parts of the machine are supplied disassembled and must be assembled.



**ASSEMBLE ALL PARTS BEFORE PLUGGING MACHINE IN.**

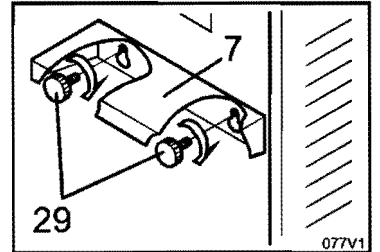
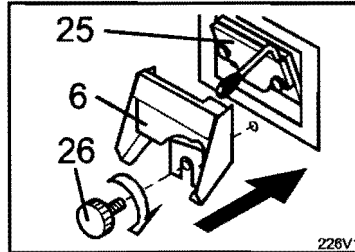
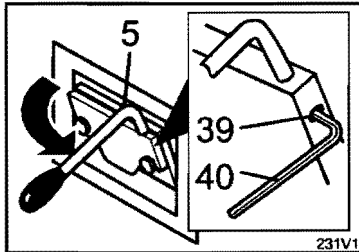

- Bring lever [5] in operative position (perpendicular to the extraction door) by loosening and then tightening bolt [39]. Use the 3mm Allen key [40] provided;
- if extraction door chute with protection flap [6] is not assembled, install it under extraction door [25] and fix it onto the front panel with the fixing knob [26];
- install basin support [7] fixing it onto front panel with fixing knobs [29].

## 6.3 Connecting to power



**THE SUPPLY VOLTAGE REQUIRED BY THE MACHINE IS HIGH AND, THEREFORE, PARTICULARLY DANGEROUS. THE MACHINE MUST BE CONNECTED TO AN ELECTRIC CIRCUIT WHICH COMPLIES WITH THE NORMS CURRENTLY IN FORCE AND IMPLEMENTED BY CERTIFIED AND QUALIFIED PERSONNEL. ALL SOCKETS MUST BE RELAYED BY ONE OR MORE DIFFERENTIAL CIRCUIT BREAKERS AND EARTHED.**

The manufacturer shall not be responsible for any damages caused by a faulty electrical supply or earthing plant.

*Note:* It is **STRONGLY** recommended to install **THREE-PHASE MAGNETO-THERMAL SWITCHES** designed to cut off power to **ALL** phases, even when overload is on one phase only. Fuses, or other magneto-thermal switches, only cut off single overloaded phases.



**If current is cut off from ONE of the THREE phases, the machine may SEEM operating, however, the motors will shortly be IRREPARABLY DAMAGED.**

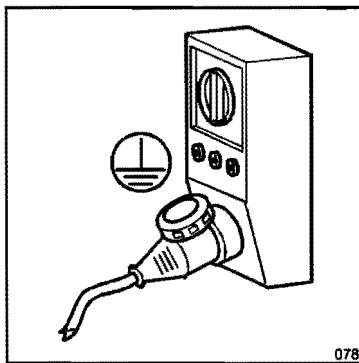

**THE CIRCUIT MUST FEATURE THE FOLLOWING CHARACTERISTICS:**

- the plant must end with an accepted 5 pole (380V-415V-3~), or 4 pole (200V-220V-3~), or 3 pole (220V-1~), electrical socket and with electrical and mechanical suitable characteristics. The electrical socket's poles must be marked with appropriate letters (phases R-S-T + neutral N + earth); the earth's pole must be recognizable;



**A WRONG CONNECTION ON EARTH POLE CAN CAUSE SERIOUS DANGER.**

- the socket must be designed to prevent the plug from being inserted incorrectly;
- there must be a **MAIN SWITCH** to cut **COMPLETELY** off power from the socket, this can be either included in the socket or within easy reach.

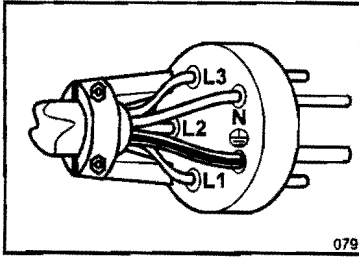

Check that the **VOLTAGE** and **FREQUENCY** written on the Technical Data plate **MATCHES** the circuit voltage and frequency.

A 5 pole (380V-415V-3~), or 4 pole (200V-220V-3~), or 3 pole (220V-1~) plug, suitable with the current socket, must be installed at the end of the device's power supply cable.

The device's power supply cable is composed by 5 or 4 or 3 coloured wires, and eventually marked with appropriate bands, which must be connected to the relevant plug's terminals, as shown in the following table.

THREE-PHASE supply (3N – 3F)	Cable colour	Cable marking	Plug marking (by terminal)
EARTH (3N – 3F)	YELLOW/GREEN	None	PE or
R phase (3N – 3F)	BLACK		R or L1
S phase (3N – 3F)	BROWN		S or L2
T phase (3N – 3F)	BLACK		T or L3
NEUTRAL (3N)	LIGHT BLUE		N



**AN INCORRECT CONNECTION INSIDE THE PLUG MAY POSE A SERIOUS RISK AND CAUSE DAMAGE TO THE MACHINE (ELECTRONIC CARDS). HAVE ALL ELECTRICAL CONNECTIONS CARRIED OUT ONLY BY CERTIFIED TECHNICAL PERSONNEL.**

#### 6.4 Connecting to water supply (water condensing machines)

If your machine is supplied with a water condensing system, supply and waste pipes must be set up.

Pipe unions are placed on the machine's rear panel, they are labelled [A] and marked:

IN: fresh water INLET

OUT: waste water OUTLET

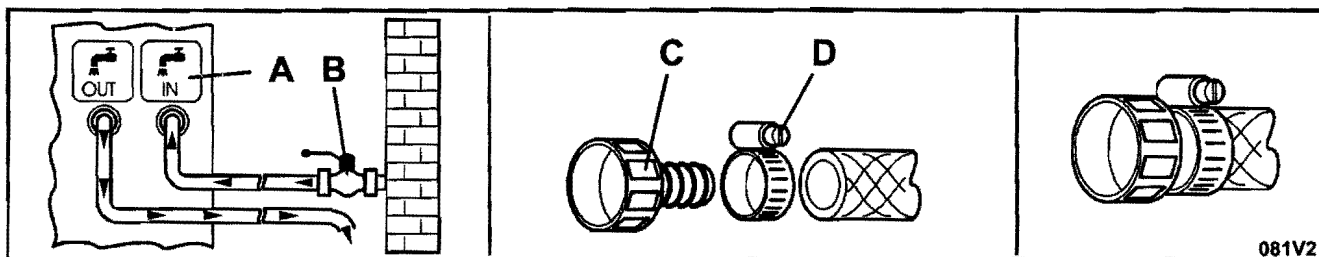

Use linen-rubber pipes suitable to bear 15 bar pressure, placing a valve or faucet [B] **BEFORE** inlet pipe; use a 3/4 rubber holder [C] tightly fixed with a band [D] to connect pipes to the machine's unions.



**Follow these precautions:**

- Do not reverse tubes and avoid tight bends and bottlenecks.
- The machine has been built to use **WELL** or **AQUEDUCT** water, at a **MAXIMUM** temperature of + 25...+28°C. Don't put hotter water (i.e. **TOWER TANK** water) in your machine if it hasn't got the **SPECIAL** system to use it (supplied only if asked): in this case, in the Technical Handbook, Par. Technical Data, it is indicated the right water temperature to use your machine.
- Unsuitable pipes and joints may cause leaks and cause damage to your workroom and, in case of major leaks and splashes, to your machine. You can easily find household appliances' pipes (i.e. washing machines') on the market, which have all the requirements, including rubber holders, as well as being economical.
- If the local water is hard and contains impurities, have a suitable water softener system or a filter fitted at the top of the inlet pipe.

- Unless otherwise specified in the Technical Handbook, inlet water pressure must be 1.5 to 6 Bar (optimal pressure: 3 Bar). If water pressure and quantity are inadequate, the machine will have **CONDENSING PROBLEMS** and will stop. If water pressure is higher, it is necessary to fit a pressure limiting device, appropriately adjusted, above the delivery pipe, otherwise machine will be **DAMAGED** or anyway it will stop working.

**i** **IMPORTANT:** When room temperature is below 0°C, remove any water from machine in order to avoid freezing inside the condenser or pipes and causing **SERIOUS DAMAGES**. Please call the authorized Assistance Service.

## 6.5 Checking rotation

**i** Once installation is complete, or if the machine is connected to another socket, check the beater's rotation.

**!** **SWITCH MACHINE OFF OR CUT OFF POWER AND CHECK THAT GREEN INDICATOR POWER  $\frac{0}{1}$  IS NOT ON!**

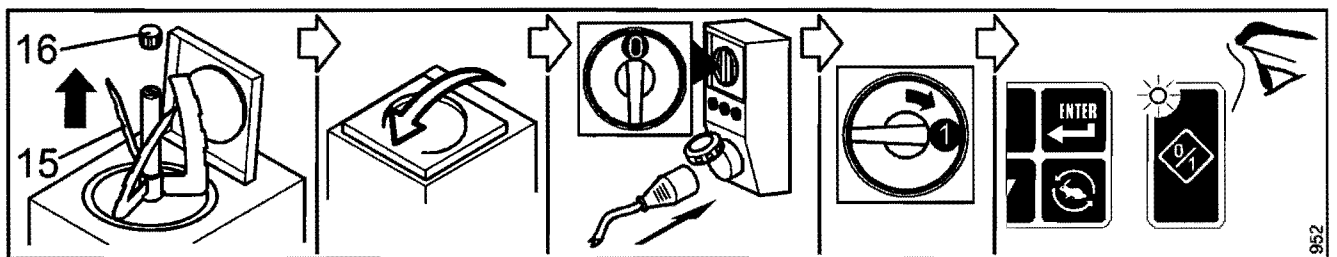

- Open the lid, unscrew the fixing knob [16], pull out the beater [15] from the tub, then close the lid;

*Note:* The machine will not operate when the lid is open or the chute with protection flap is not in place.

- plug machine in and switch socket breaker on;
- only POWER  $\frac{0}{1}$  indicator must come on the control panel;

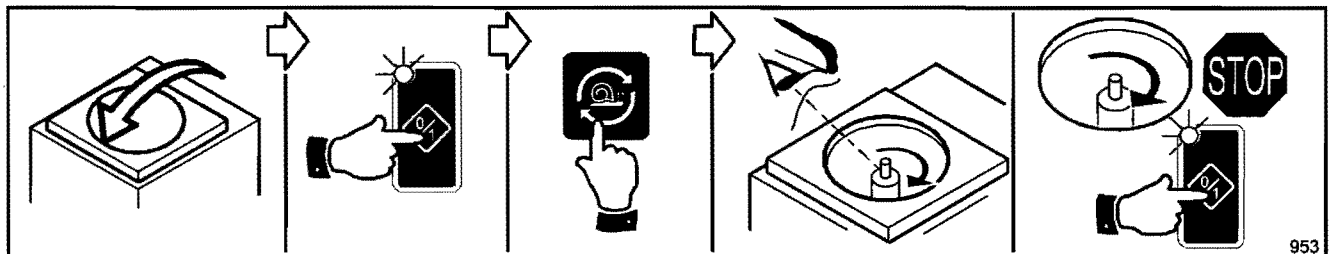

- press ON/OFF  $\frac{0}{1}$ . The display will come on;
- press SLOW MIXER button and check (through clear lid) that the beater's shaft is **CORRECTLY** rotating **CLOCKWISE**. Press SLOW MIXER again to stop beater;
- press ON/OFF  $\frac{0}{1}$  to turn machine off;

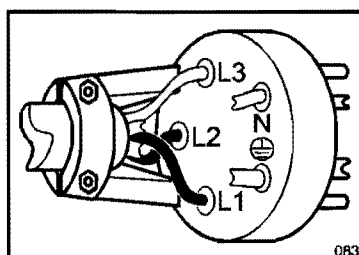

- If rotation is **COUNTERCLOCKWISE (WRONG)**, power connection must be modified as follow:



**TURN THE SOCKET'S MAIN SWITCH TO "0" AND UNPLUG.**

- open plug and reverse **TWO** out of **THREE** wires connected to PHASES (R-S, R-T or S-T);
- close plug, turn machine on and repeat test;

- If rotation is **CLOCKWISE (right)** then the machine is ready to be used: fit beater [6] back into the tub.

**i** The beater's fixing knob [7] must be **FIRMLY TIGHTENED**.

## 7 USING THE EQUIPMENT

### 7.1 Warnings



**WHEN USING THE DEVICE, AS WITH ALL ELECTRICAL APPARATUS, ESSENTIAL RULES MUST BE COMPLIED WITH, PARTICULARLY:**

- never touch it if your feet or hands are wet;
- never operate it while barefoot;
- never pull the supply cable to disconnect it from the mains network;
- avoid liquids to penetrate in the device, for example during its cleaning;
- forbid children and unable people to operate it.

In case of failure and/or malfunctioning of the device - and every time you notice damages, mainly at the supply cable or at the safety devices - turn off the power supply. Contact qualified and certified personnel for assistance.



**EDIBLE FATS ARE GROUND FOR BACTERIA PROLIFERATION. WE RECOMMEND TO WASH AND CLEAN WITH THE MAXIMUM CARE EVERY PART IN CONTACT WITH PRODUCT, WHEN THE USE OF THE DEVICE IS SUSPENDED.**



**NEVER operate the machine in DRY conditions or with an amount of mixture other than the one recommended.**



**NOT RESPECTING THESE RULES, IN ADDITION TO VOIDING ANY FORM OF WARRANTY, CAN SERIOUSLY COMPROMISE THE SAFETY, PERFORMANCES AND FUNCTIONING OF THE SAME DEVICE.**

The machine is designed to operate two separate main Cycles: the TEMPERATURE CYCLE and the TIME CYCLE:

- with Temperature Cycle the machine cools the mixture down to Final Temperature [Tf] which is set to the desired final thickness;
- with Time Cycle the machine cools the mixture down according to Whipping Time [M] which is set according to the product's quantity and type.

Before starting production, we recommend to carefully read Par. 6.2 - "Controls and Indicators" and Par. 6.3 - "Setting Up" of this manual.

### 7.2 Controls and info / warning lights

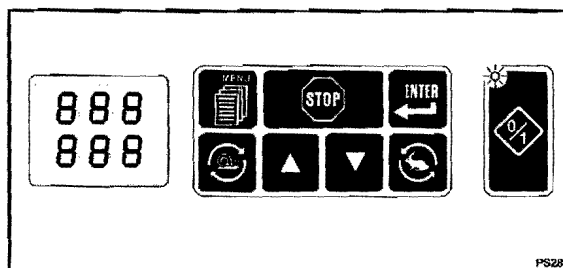

#### Control panel

All equipment controls and info/warning lights have been grouped together on a single control panel. This is located on the frontal panel. The control panel is an electronically controlled low-voltage device.

There follows a detailed description of all the individual controls; it is recommended that you become familiar with them here so as to ensure the best possible production results.



**ON/OFF ke  
POWER indicator light**

This key is used to switch the equipment on or off. When the equipment is connected to the mains power supply the POWER indicator light  is always on..



### MENU' Key

Allows user to display the various equipment functions. A more detailed description of how to use this key is provided in Section 8 - Program settings



### STOP Key

Allows user to stop fast  or slow  mixing.

In the menu functions , this key returns the user to the previous screen.



### SELECTION Key

These keys only work after pressing ON/OFF  and allow the various programs to be displayed. Pressing them allows the user to scroll the various programs and selected data. When in menu functions this key is used to select the data and functions requested by the programme. For more details on its use see Sect. 8 – Program settings.



### FAST MIXING Key

Pressing this key manually activates/deactivates fast mixer rotation.



### SLOW MIXING Key

Pressing this key manually activates/deactivates slow mixer rotation.



### ENTER Key

This key activates processing after selecting the programme. Also used to confirm selected data in the menu function . For more details on its use see Section 8 – Program settings.

## 8 PROGRAM SETTINGS

### 8.1 Language selection and Key to symbols

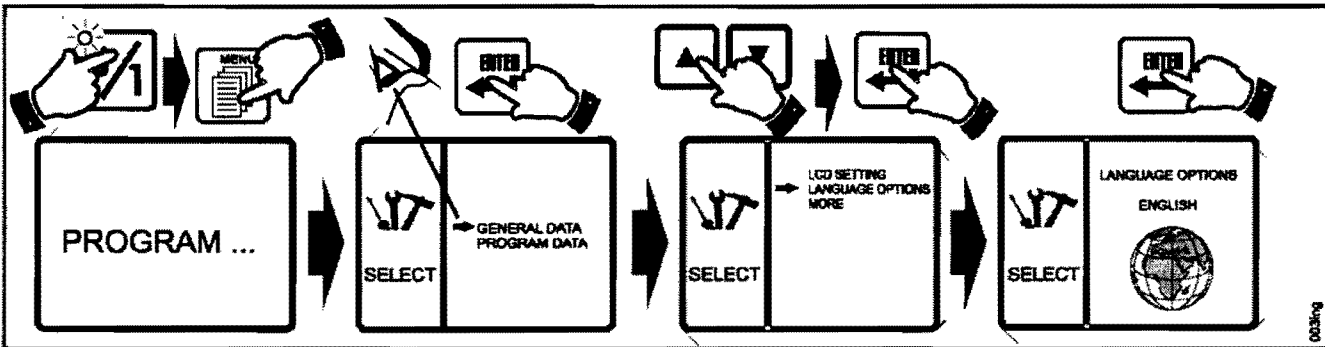

- Press the ON/OFF key . The display shows the last programme selected: then press the MENU ' key , and 2 options appear on the display;
- carefully observe the position of the arrow on the left side of the options, select the GENERAL DATA option using the keys and press ENTER ;
- on the following page select the LANGUAGE using the keys and press ENTER , select the desired language and then press ENTER again;

#### Key to symbols

HEATING; HOLDING TIME; COOLING; MIXER; SLOW MIXER; MIXER AND STANDSTILL / RETURN; FAST MIXER; INTERMITTENT MIXER; EXTRACTION;



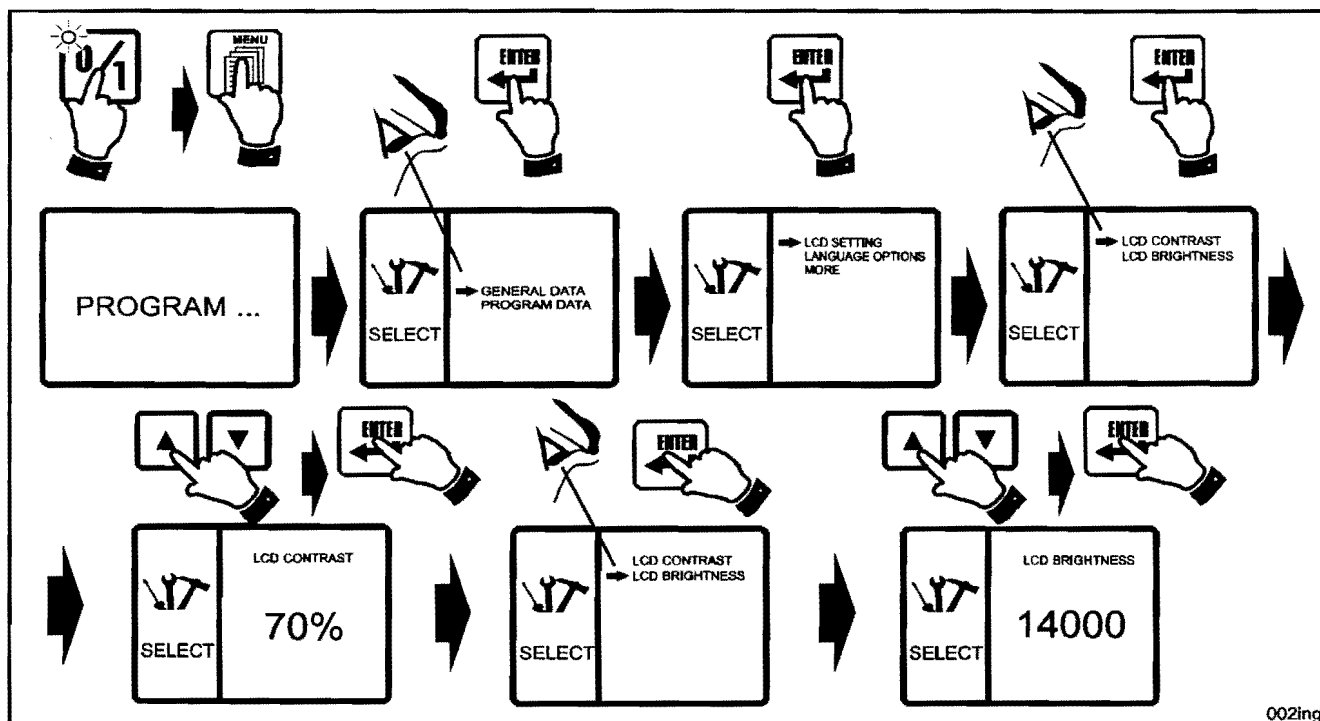



## 8.2 LCD Adjustment

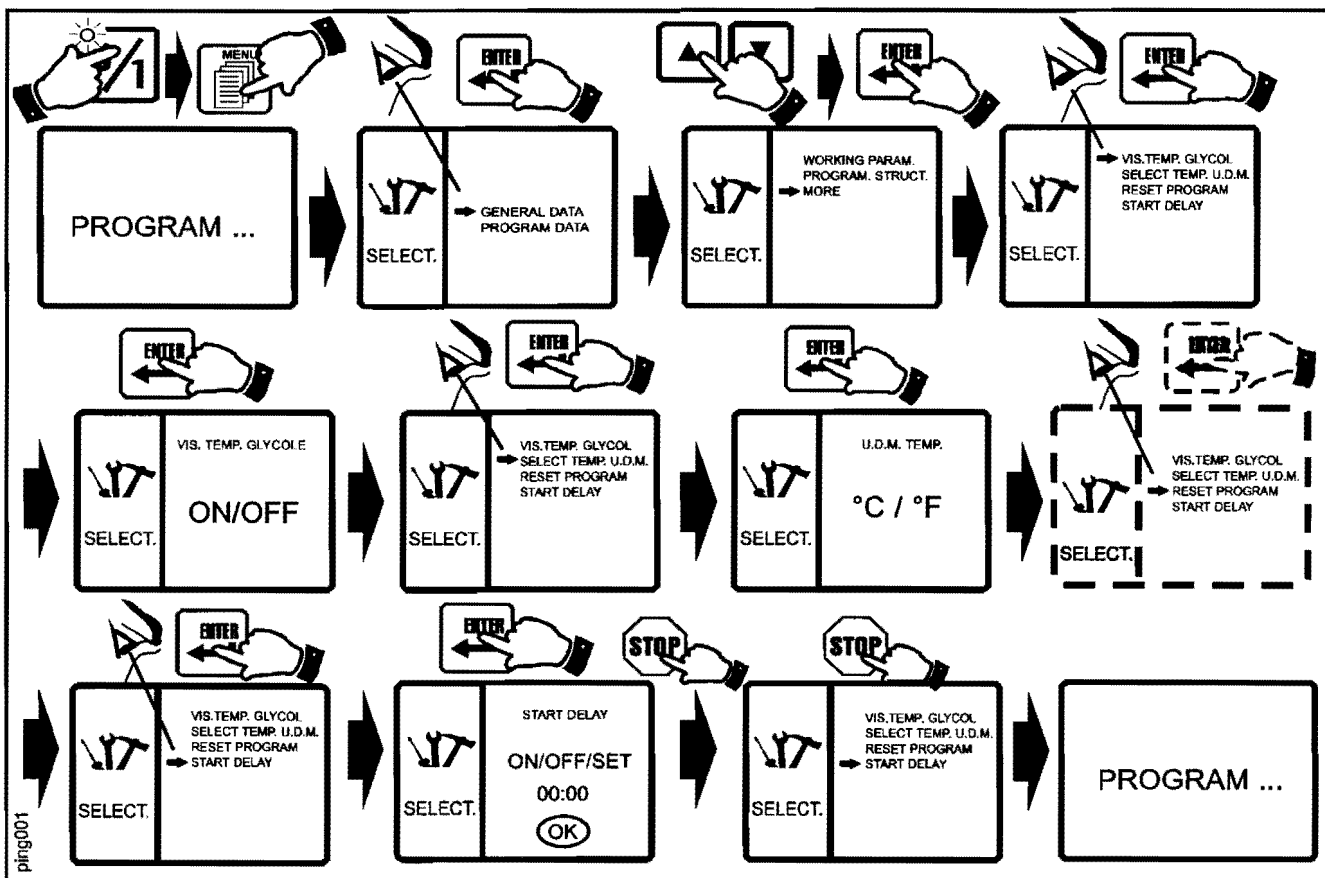

- Press the ON/OFF key. The display shows the last programme selected: then press the MENU key and 2 options appear on the display;
- carefully observe the position of the arrow on the left side of the options, select the GENERAL DATA option using the keys and press ;
- on the following page select the LCD SETTINGS option using the keys and press ENTER ;
- the following options are LCD CONTRAST and LCD BRIGHTNESS. Contrast increases/decreases the intensity of the legends while brightness increases/decreases the display background. Use the keys to select first one option then the other;
- after selecting CONTRAST a percentage adjustment appears on the display: adjust as desired using the keys and press ENTER . After selecting BRIGHTNESS a numbered adjustment appears on the display, adjust as desired using the keys.

## 8.3 General data - more



- Press the ON/OFF key  $\frac{1}{2}$ . The display shows the last programme selected: then press the MENU key , and 2 options appear on the display;
- carefully observe the position of the arrow on the left side of the options, select the GENERAL DATA option using the   keys and press ENTER ;
- on the following page select the EXTRA option using the   keys and press ENTER ;
- the following options are GLYCOL TEMPERATURE DISPLAY, TEMPERATURE U.o.M. SELECTION, PROGRAMME DATA RESET (only preset programmes from programme 1 to programme 5);
- select item GLYCOL TEMPERATURE DISPLAY and select ON/OFF if you want to view the temperature on the display during operations, select TEMPERATURE U.D.M. to view the temperature in CELSIUS or FAHRENHEIT, select RESET only if you want to zero set any values that have been changed for the pre-set programs (from 1 to 5), select START DELAY if you want to delay machine start. When you select START DELAY machine start is delayed and therefore so is production, enter a time after which you want the machine to start (expressed in minutes).

## 8.4 Working parameters

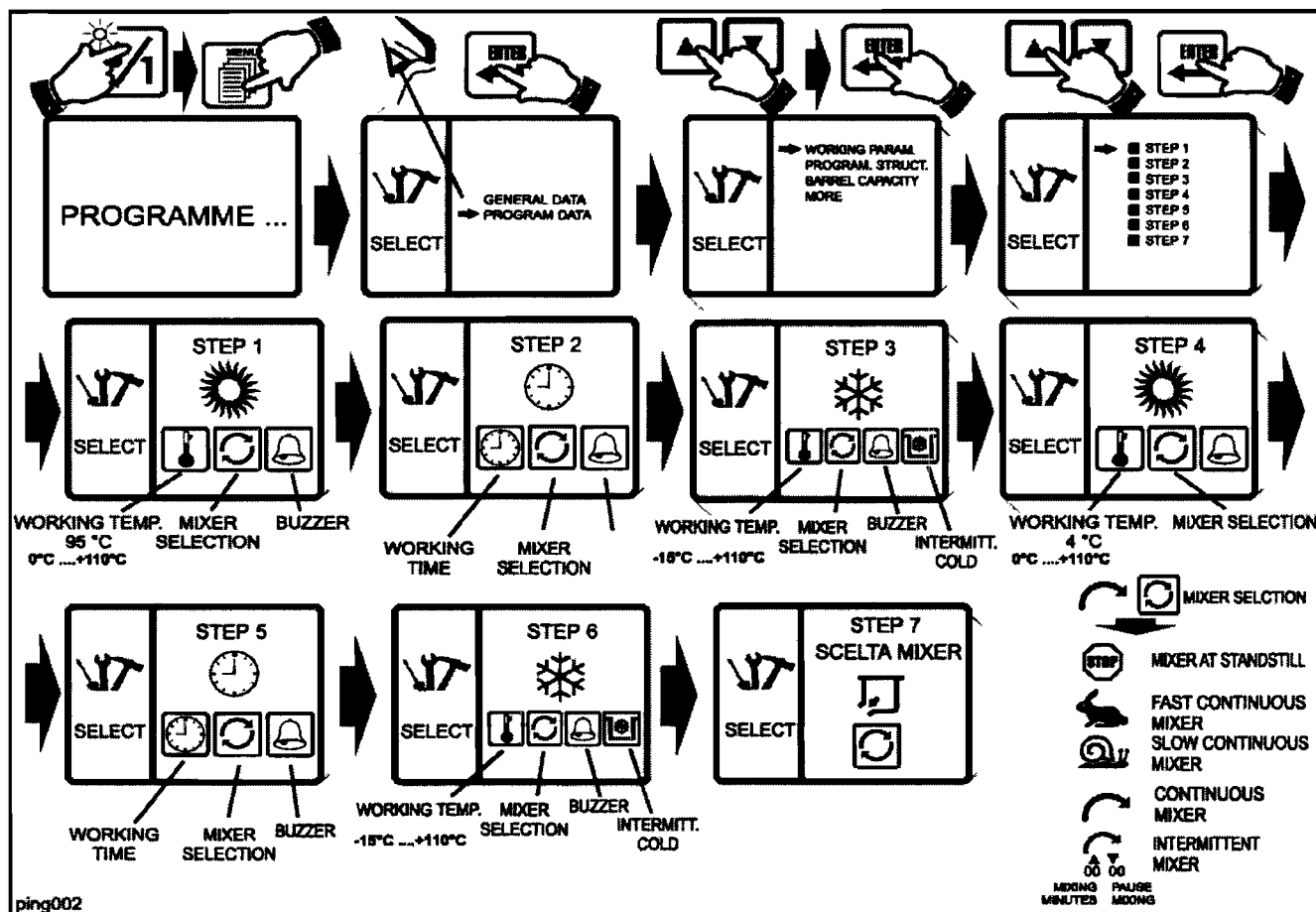



- Press the ON/OFF key . The display shows the last programme selected: then press the MENU key and 2 options appear on the display;
- carefully observe the position of the arrow on the left side of the options, select the PROGRAMME DATA option using the keys and press ENTER .
- on the following page select the WORK PARAMETERS option using the keys and press ENTER . The display will show 7 processing stages; use the keys to shift the cursor to the desired stage, press ENTER and proceed with setting as follows;

### STEP 1 (HEATING)





















- Set final heating temperature using the keys then press ENTER to confirm; the adjustment range is +0 °C .... + 110 °C;
- set the MIXER type by scrolling through the 2 mixer types using the keys; these are SLOW MIXER (continuous low speed mixing), INTERMITTENT MIXER (slow mixing with pauses). Then press ENTER to confirm the choice. The product in the vat will be heated to the set final temperature and creamed with the chosen mixer setting. If, on the STEPS STRUCTURE one or two mixer changes have been set, the programme requests one or two different mixer types and the temperature at which the product creaming change is to be carried out;
- set the BUZZER , if activated once in PHASES STRUCTURE it comes on at the set final heating temperature. Use the keys to raise or lower the temperature at which the BUZZER is tripped a second time; select a temperature between 0 °C and the set final temperature. Press the STOP key to return to the STAGES page.

### STEP 2 (HOLDING TIME)









- Set the holding time using the keys and then press ENTER to confirm, the range of adjustment is 0 ... 999. Once set final temperature has been reached the product in the vat is held at that temperature for the set duration of this stage. Set the MIXER type by scrolling through the 2 mixer types using the keys; these

are SLOW MIXER  (continuous low speed mixing), INTERMITTENT MIXER  (slow mixing with pauses). Then press ENTER  to confirm the choice. To change mixer and/or sound warning buzzer enter delay time from the start of holding time in this phase. The product in the container is kept at the heating temperature set in PHASE 1 with the type of mixer chosen in this option, for the time set in this phase (expressed in minutes). Press stop key to return to the phase display.





### STEP 3 (COOLING)







- set the type of cooling with keys  , choose continuous cooling  or intermittent cooling . Continuous cooling keeps the refrigeration unit ON continuously while intermittent cooling alternates the cooling function with a pause, to adjust the seconds of pause (on right) and function (on left) use keys  , then set the final cooling temperature again using keys  , press ENTER  to confirm the selection, the temperature range within which adjustment can be made is +109 °C ... - 15 °C;
- set the MIXER type  by scrolling through the 2 mixer types using the   keys; these are SLOW MIXER  (continuous low speed mixing), INTERMITTENT MIXER  (slow mixing with pauses). Then press ENTER  to confirm the choice. The product in the vat will be cooled to the set final temperature and creamed with the chosen mixer setting. If, on the STEPS STRUCTURE one or two mixer changes have been set, the programme requests one or two different mixer types and the temperature at which the product creaming change is to be carried out;
- set the BUZZER , if activated once in PHASES STRUCTURE it comes on at the set final cooling temperature. Use the   keys to raise or lower the temperature at which the  is tripped a second time; select a temperature between -15 °C and the set final temperature. Press the STOP key  to return to the STEPS page.





### STEP 4 (HEATING)

- set final heating temperature using keys  , then press ENTER  to confirm, the range of adjustment is +0 °C ... + 110 °C;
- set the MIXER type  by scrolling through the 2 mixer types using the   keys; these are SLOW MIXER  (continuous low speed mixing), INTERMITTENT MIXER  (slow mixing with pauses). Then press ENTER  to confirm the choice. The product in the vat will be heated to the set final temperature and creamed with the chosen mixer setting. If, on the STEPS STRUCTURE one or two mixer changes have been set, the programme requests one or two different mixer types and the temperature at which the product creaming change is to be carried out.

















### STEP 5 (HOLDING)

- set the temperature holding time using keys  , then press ENTER  to confirm. It is possible to change the mixer and sound the BUZZER  after activating the option in ACTIVE PHASES.









Set the type of MIXER  scrolling with keys   the 2 types of mixer, SLOW MIXER  (continuous low speed mixing) or INTERMITTENT MIXER  (mixing alternated with pause) press ENTER  to confirm the choice. (see PHASE 2).

When the final heating temperature is reached (PHASE 4), the product in the container stays at the temperature for a time set in this phase, the range of adjustment is 0 ... 999 minutes. To change the mixer and/or sound the warning buzzer, enter the delay time from the beginning of temperature holding time using keys   to increase or reduce the time and press ENTER  to confirm. Press stop  to return to the phase display.

### STEP 6 (COOLING)

- set the type of cooling with keys  , choose continuous cooling  or intermittent cooling . Continuous cooling keeps the refrigeration unit ON continuously while intermittent cooling alternates the cooling function with a pause, to adjust the seconds of pause (on right) and function (on left) use keys  , then set the final cooling temperature again using keys  , press ENTER  to confirm the selection, the temperature range within which adjustment can be made is +109 °C ... - 15 °C;
- set the MIXER type  by scrolling through the 2 mixer types using the   keys; these are SLOW MIXER  (continuous low speed mixing), INTERMITTENT MIXER  (slow mixing with pauses). Then press ENTER  to confirm the choice. The product in the vat will be cooled to the set final temperature and creamed with the chosen mixer setting. If, on the STEPS STRUCTURE one or two mixer changes have been set, the programme requests one or two different mixer types and the temperature at which the product creaming change is to be carried out;
- set the BUZZER , if activated once in PHASE STRUCTURE it sounds at the final cooling temperature set, use the keys to raise or lower the temperature at which you want the BUZZER  to sound a second time, select a temperature between -15° and the final temperature set. Press stop key to return to the phase display.

### STEP 7 (EXTRACTION)

- set the MIXER type  by scrolling through the 2 mixer types using the   keys; these are MIXERAT , FAST MIXER  (continuous high speed mixing), SLOW MIXER  (continuous low speed mixing). Then press ENTER  to confirm the choice. The product in the container is extracted at high or low speed according to the type of mixer chosen in this option. Press stop key  to return to previous display.

## 8.5 Programme structure

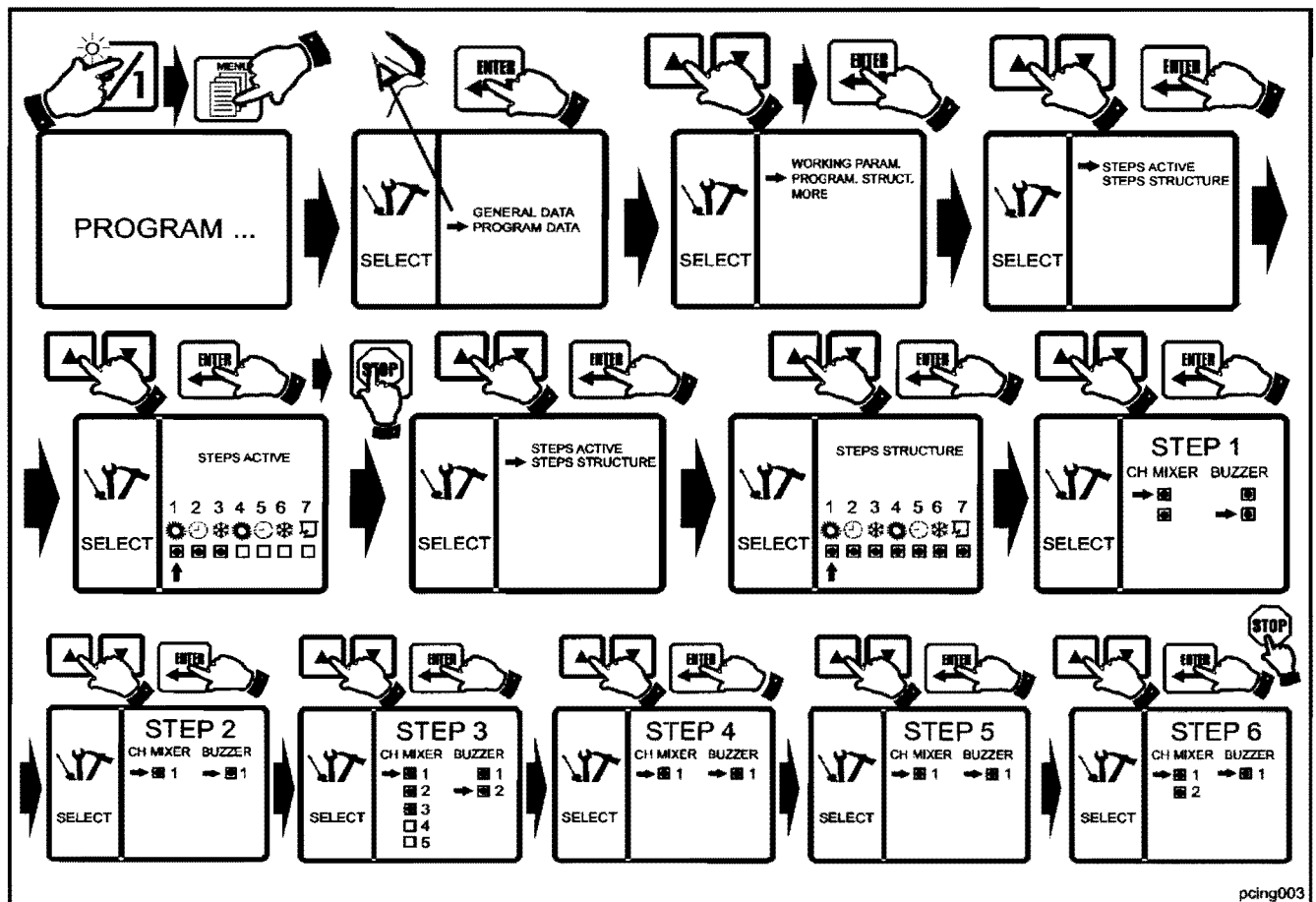

pcing003

- Press ON/OFF key  $\frac{0}{1}$ , the display shows the last program selected, then press MENU key, 2 options appear on the display;
- observe carefully where the arrow is positioned to the left of the options, select with keys the PROGRAM DATA option and press ENTER ;
- on the next display use keys to select PROGRAM STRUCTURE option and press ENTER , the display shows 2 options PHASES ACTIVE and PHASE STRUCTURE, use keys to move the arrow to the desired phase and press ENTER setting as follows:



### ACTIVE PHASES

- use keys to select the phases to activate in making the product, then ENTER to confirm the choice. The phases activated are to be set in PHASE STRUCTURE.



### PHASE STRUCTURE



- the phases to set are: 1 HEATING , 2 HOLDING , 3 COOLING , 4 HEATING , 5 HOLDING , 6 COOLING ;

In PHASE 1 it is possible to carry out 2 changes of mixer (type of product whipping) that take place at the temperature set in OPERATING PARAMETERS, 2 activations of BUZZER at 3 different heating temperatures between 0°C and the final temperature set;

in PHASE 2 it is possible to carry out 1 change of mixer (type of product whipping) that take place at the temperature set in OPERATING PARAMETERS, 1 activation of BUZZER  at 1 different temperature between the heating temperature  set in PHASE 1 and final cooling temperature set in PHASE 3 at a time set in this phase in OPERATING PARAMETERS;





in PHASE 3 it is possible to carry out 5 changes of mixer (type of product whipping) that take place at the temperature set in OPERATING PARAMETERS, 2 activations of BUZZER  at 2 different cooling temperatures between the heating temperature and final cooling temperature set in OPERATING PARAMETERS;

in PHASE 4 it is possible to carry out 1 change of mixer (type of product whipping) that takes place at the temperature set in OPERATING PARAMETERS (PHASE 3), and 1 activation of BUZZER  at 1 different heating temperature ;

in PHASE 5 it is possible to carry out 1 change of mixer (type of product whipping) that takes place at the temperature set in OPERATING PARAMETERS and 1 activation of BUZZER  at 1 different temperature; between heating temperature  set in PHASE 4 and final cooling temperature set in PHASE 6 at a time set in this phase in OPERATING PARAMETERS.

In PHASE 6 it is possible to carry out 2 changes of mixer (type of product whipping) that take place at the temperature set in OPERATING PARAMETERS, 1 activation of BUZZER  at 1 different cooling temperature;

## 8.6 Program from 1 to 5 (preset)

- Press the ON/OFF key . The display shows the last programme selected; then press the   keys to display the 14 automatic preset programmes and choose the most suitable according to the product to be processed. Then press ENTER  to confirm and activate processing.
- The 5 automatic programmes have been set for different product types. To aid the right choice there follows a list of their characteristics and functions:

### PROGRAM 1

- PHASE 1 - heating  at + 82°C, mixer , buzzer  at + 82°C; PHASE 3 - cooling  at - 8,0 °C , mixer , buzzer  at - 8,0 °C; PHASE 7 - extraction  with FAST MIXER ;

### PROGRAM 2

- PHASE 1 - heating  at + 72°C, mixer , buzzer  at 72°C; PHASE 3 - cooling  at - 9,0 °C , mixer , buzzer  at - 9,0 °C; PHASE 7 - extraction  with FAST MIXER ;













### PROGRAM 3

- PHASE 3 - cooling  at - 8,0 °C , mixer , buzzer  at - 8,0 °C; PHASE 7 - extraction  with FAST MIXER ;

### PROGRAM 4

- PHASE 3 - cooling  at - 9,0 °C , mixer , buzzer  at - 9,0 °C; PHASE 7 - extraction  with FAST MIXER ;

### PROGRAM 5

- PHASE 1 - heating  at + 95°C with mixer , buzzer  at + 95°C; PHASE 2 - holding  for 5' with mixer ; PHASE 3 - cooling  at + 6 °C with intermittent mixer  (10" on, 50" off), change mixer  (20" on, 40" off) at + 60 °C, change intermittent mixer  (30" on, 60" off) at + 25 °C; change mixer  at + 10 °C, buzzer at + 6 °C; PHASE 7 - extraction  with FAST MIXER ;

## 8.7 Saving free programmes (from 6 to 24)

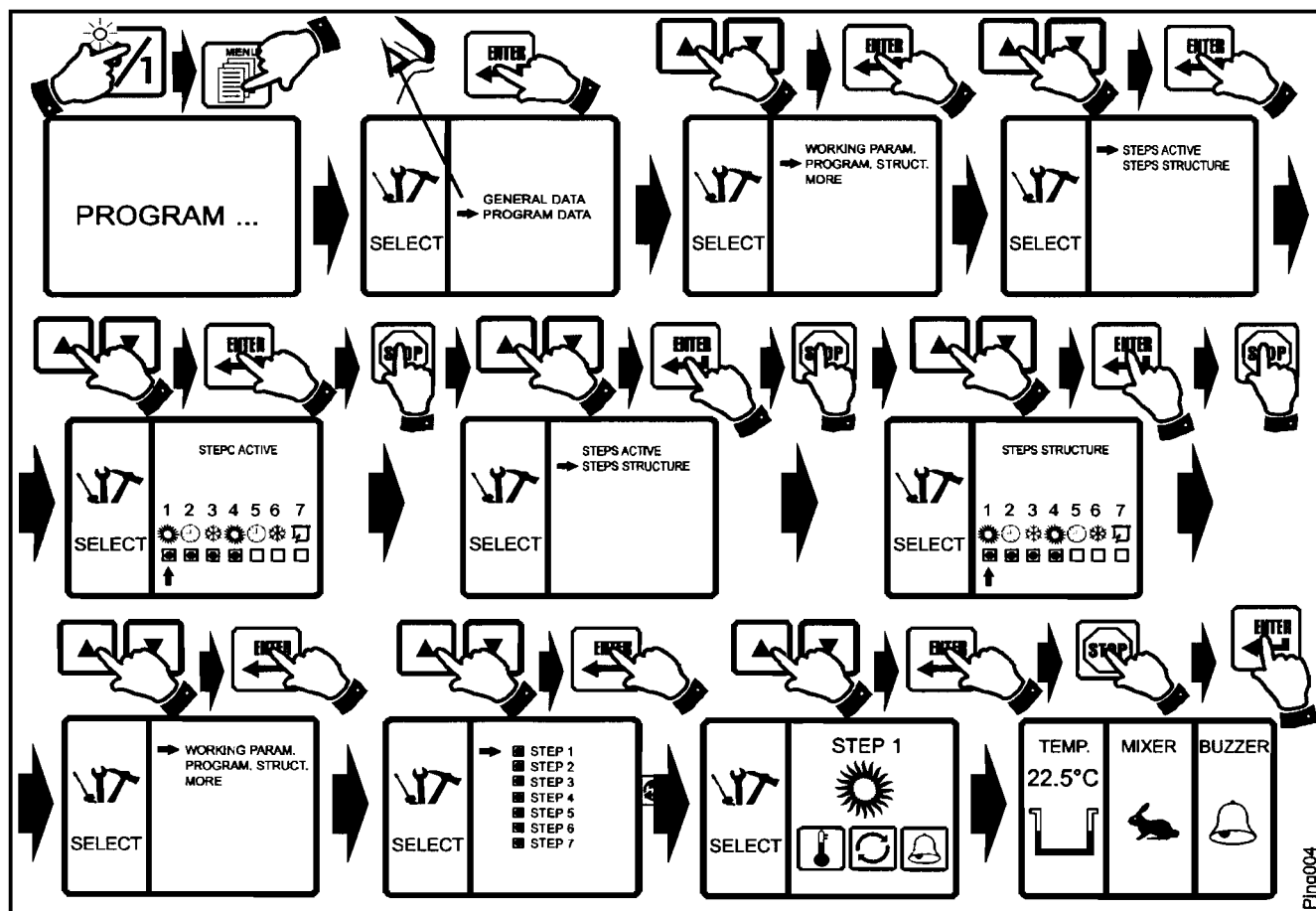

- Press the ON/OFF key . The display shows the last programme selected: then press the MENU key and 2 options appear on the display;
- carefully observe the position of the arrow on the left side of the options, select the PROGRAM DATA option using the keys and press ENTER ;
- on the next page use the keys to select PROGRAM STRUCTURE and press ENTER . Firstly, shift the cursor to ACTIVE STAGES and press ENTER , programme the desired stages (according to the products to be processed) and confirm with the ENTER key. Then press the STOP key to proceed to STAGE STRUCTURE settings to carry out a MIXER change and/or use the BUZZER during processing.
- proceed by pressing the STOP key and returning to the screen indicating WORK PARAMETERS; confirm by pressing ENTER , using the keys to set the values for the ACTIVE STAGES.
- using the STOP key, return to the main menu showing the programme with relative number then press ENTER to proceed with processing;
- keep a written record of the programme number and relative settings so they can be re-entered if necessary.

## 9 PREPARING MACHINE FOR PRODUCTION AND GENERAL INFORMATION



**WARNING:** AT THE BEGINNING OF EACH OPERATING CYCLE INSPECT THE SAFETY SYSTEM TO CHECK THAT THE CONTROL UNIT IS FUNCTIONING EFFICIENTLY. RUN THE MACHINE EMPTY, THEN OPEN AND CLOSE THE MACHINE LID, TO CHECK THAT THE SAFETY COMES ON AND LOCKS THE MIXER SHAFT.

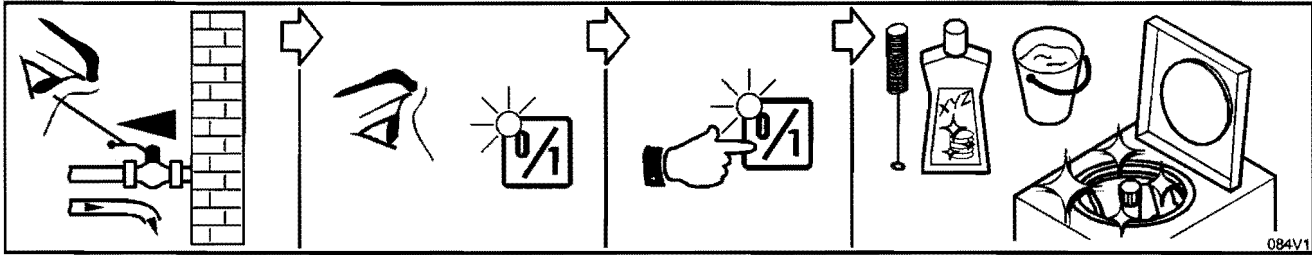

- In case of machines supplied with water condensing, check that water supply faucet is open;
- check POWER  $\frac{0}{1}$  indicator is lit. If not, check that machine is plugged in and Main Switch is on;
- press ON/OFF  $\frac{0}{1}$ ;



**BEFORE UNDERTAKING PRODUCTION, THE MACHINE MUST BE THOROUGHLY WASHED AND SANITIZED (SEE CHAPTER 8).**

*Note:* If you plan to carry out more than one consecutive production cycle of the same product, you can avoid washing between cycles.



**Do not operate beater in dry condition. Doing so could cause damage.**

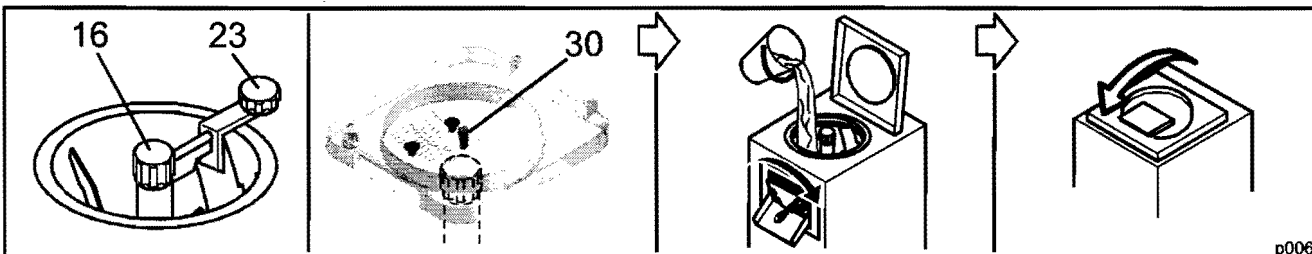

**Before starting production ALWAYS check that beater's fixing knob [16] and the tilting blade's fixing knob [23] (when supplied) are FIRMLY TIGHTENED and that all the relevant gaskets are intact and clear of any fat. If the knobs should accidentally unscrew and fall in the tub during the functioning, they would cause serious damages to the machine.**

*Note:* A safety rod [30] is placed in the middle of the lid. The rod will lift lid (and stop machine) in case the knob [16] becomes loose.



**Unsuitable mixture or insufficient amount of it can cause excessive overheating or the development of ice, and cause damages or irregular functioning at the tub and beater, while an excessive amount of mixture can forbid the correct whipping, in addition to causing an excessive stress at the motor and beater and overflows of product.**

- check that the extraction door is firmly closed and pour ingredients in the tub. Only use the appropriate fresh ingredients:

Machine model	Total mixture in tubs (Min...Max)		
	ICE-CREAM	CREAM	CRUSHED-ICE
3 - 6	3...6 litres	4...8 litres	4...8 litres
4 - 8	4...8 litres	6...12 litres	6...12 litres

- close lid;

## 10 WASHING AND SANITATION

### 10.1 Rinse - preliminary wash

The beater, the tub and the extraction lid can be quickly rinsed.

This procedure is recommended:

- between consecutive cycles;
- to have easy access to the machine's components before disassembling (in order to prepare machine for washing and sanitation operations).



**QUICK RINSING IS NOT SUFFICIENT TO ENSURE HYGIENE.**

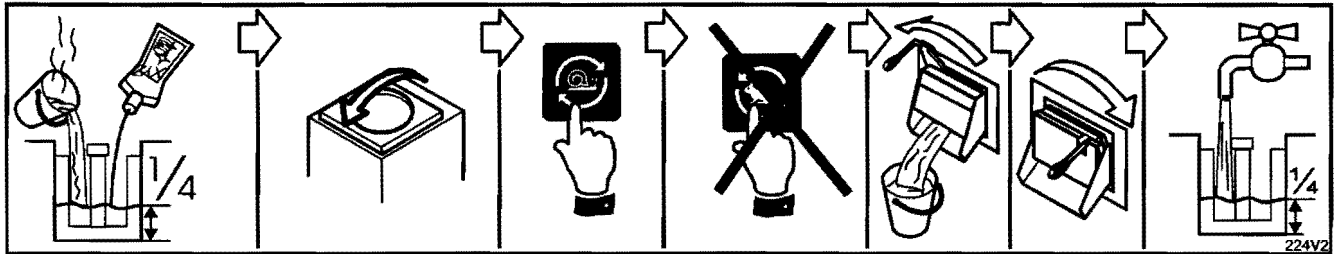

- Close extraction door. A quarter of tub with warm water;
- close lid and press BEATING . Stop beater after a while;



**Do not operate beater for long periods of time during washing. Lack of lubrication (ordinarily provided by the ingredients during production) may damage and wear the beater or the tub.**



**Do not unnecessarily turn refrigerating system on.**

- Stop beater, place a container under the extraction door and slowly open it to let water out of the tub.

### 10.2 Parts disassembling

To simplify washing procedures, all those parts coming into contact with the product can be quickly and effortlessly dismantled by the operator, without the aid of any tool.

- Carry out preliminary washing operations (ref. Par. 8.1) for easy access to all parts.



**IT IS DANGEROUS TO CARRY OUT THE FOLLOWING OPERATIONS WHILE MACHINE IS POWERED. TURN MAIN SWITCH OFF BEFORE PROCEEDING.**

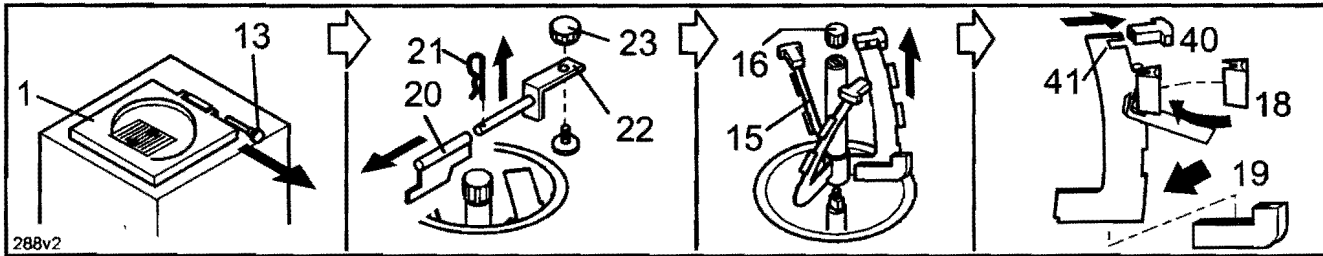

- Remove pin [13] from hinge and remove lid [1].
- Remove and disassemble the movable blade. Proceed as follow:
  - unscrew knob [23] and remove the entire movable blade section;
  - remove movable blade [20] from its support [22] by removing safety peg [21].
- Remove and disassemble beater:
  - unscrew knob [16] and pull central hub to remove beater [15]

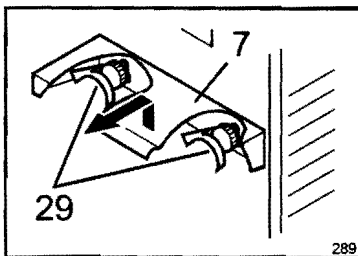

- remove bottom scraper [19] from the beater's blade;
- remove the adaptation runners [40] from the center [41];
- turn all side scrapers [18] to remove them from beater's blades.
- Remove basin support:
  - loosen knobs [29];
  - pull basin support [7] up to remove it.
- Do not remove flap chute as yet.

### 10.3 Washing

You must thoroughly wash and sanitize all parts which come into contact with the product to comply with the current norms in force.

- DO NOT USE:
  - NON-FOOD COMPATIBLE cleaning products;
  - Any SOLVENT (they are poisonous, flammable and can damage the machine's plastic components);
  - ABRASIVE cleaning products and brushes.



**DO NOT DO THE FOLLOWING OPERATIONS WHEN MACHINE IS ON.**



**DO NOT ALLOW WATER OR LIQUIDS THROUGH THE SIDE OPENINGS AND THE BACK FAN/CONDENSER TO PREVENT THE INTERNAL COMPONENTS' (MOTORS, FANS, COMPRESSOR, ELECTRIC WIRING) GETTING WET.**

*Extra care should be taken with all AIR condensing system machines, as there are wide condenser holes on the back panel and wide side holes.*

- Clean with care all machine's parts which come into contact with the product: inside tub, extraction door and outlet pipe. Use food-compatible detergents, warm water and /or steam jet:

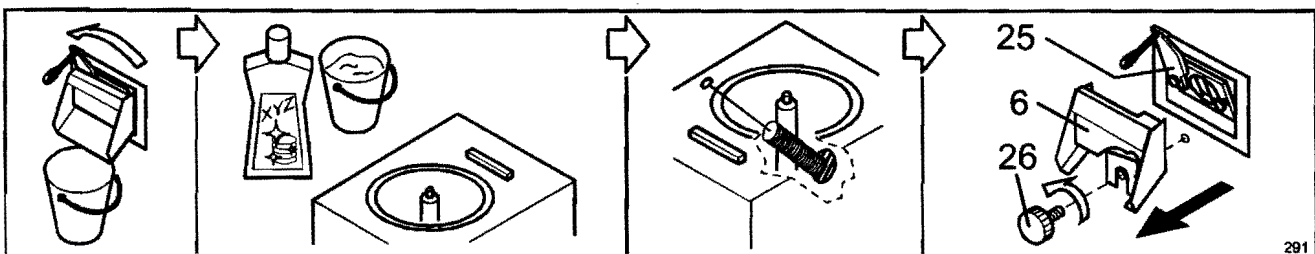

- place a container under chute and open extraction door;
- wash tub inside;
- clean outlet tube and its grill. Use the tube brush supplied and clean from inside the tub;

- unscrew knob [26] and remove chute with protection flap [6]. Put all components aside together;
- clean extraction door [25];
- dry all components.

— Clean outside surfaces:

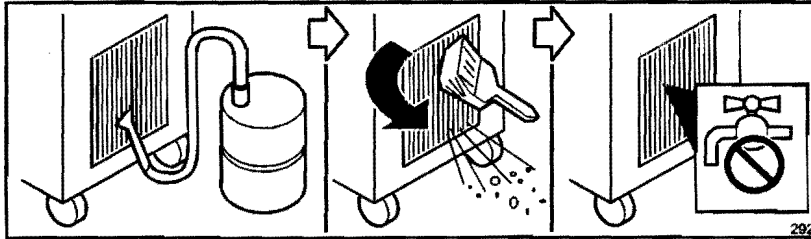

- in case of an air condensing system, DRY remove dust and grime from the condensers' grills (on the back panel). Firstly, vacuum clean and then, if necessary, use a soft brush to remove any remaining dust working FROM THE INSIDE OUT;



**Do NOT use liquid products (dust would become stuck on the condenser) and do NOT push dust INSIDE, to avoid damage to the refrigerating system and dropping of its performance. Air condenser is SUCTION type, therefore dirt accumulates on the outer side and must be removed away from it.**

- clean side panels and back panel;
- clean front panel in all its parts.

— Separately wash ALL other components previously disassembled (par. 8.2). You can either wash them in a dishwasher or by hand in warm water with a food-compatible detergent. Rinse with fresh water and dry.

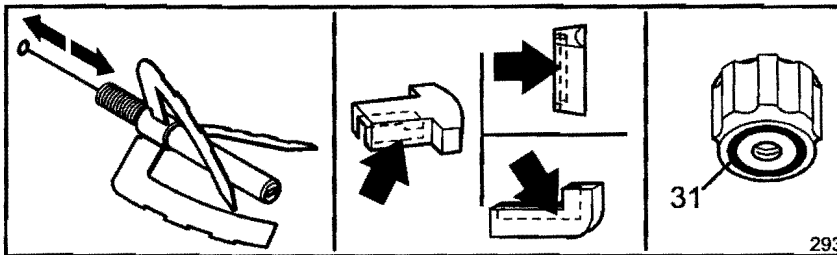

**Remember to:**

- CAREFULLY CLEAN inside the central hub with the tube brush supplied.
- Remove any product traces from the plastic scrapers with a brush.
- Wash and remove grease from the beater and the movable blade fixing knob's gaskets [31].

- Wash chute with protection flap. Do NOT dismount it.
- Wash lid taking care not to scratch it with abrasive products or brushes. Do NOT remove grill and small steel lid from the lid.
- Wash the lids, avoiding the use of rough objects which might scratch them.

## 10.4 Parts reassembling

— Assemble and install the beater:

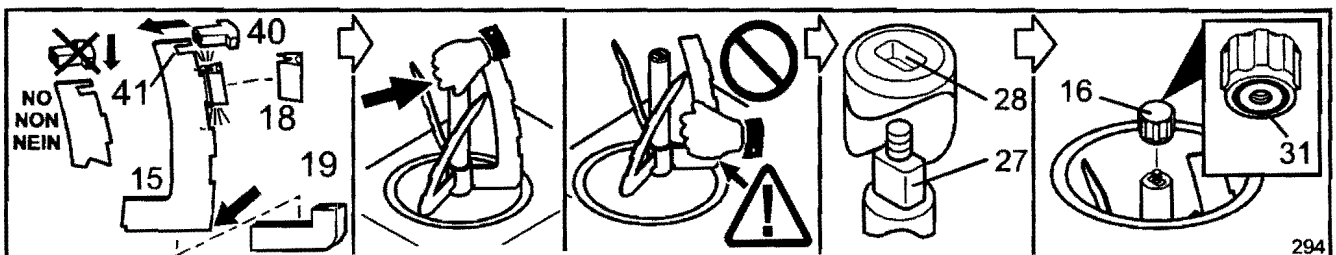

- Snap ALL side scrapers [18] on beater's blade [15]. They must click on. If you do not hear a clicking noise the scraper may be damaged or worn and therefore needs replacing.
- put bottom scraper [19] onto the blade with the SHARP edge [15]. It is possible that bottom scraper needs to be kept in place, due to the normal wear of its seating: check it for damages;
- proceed to place the beater in the tub by holding ONLY the central hub and keeping it in an upright position and taking care not to drop it. Check that the blades are in the correct position.



**DO NOT HOLD BEATER'S BLADES! IT COULD BE HARMFUL FOR YOUR HANDS WHEN YOU INSERT IT!**

- insert the beater's hub slot [28] into the shaft's graft [27];
- FIRMLY tighten the beater's knob [16].



Always make sure that the fixing knob's [16] gasket [31] is in good condition and firmly in place. Moreover it should **NOT BE GREASY**; this is necessary to prevent the knob accidentally becoming loose. If the gasket is worn, replace it immediately as it would cause great **DAMAGE** to the machine if the knob fell in the tub during production.

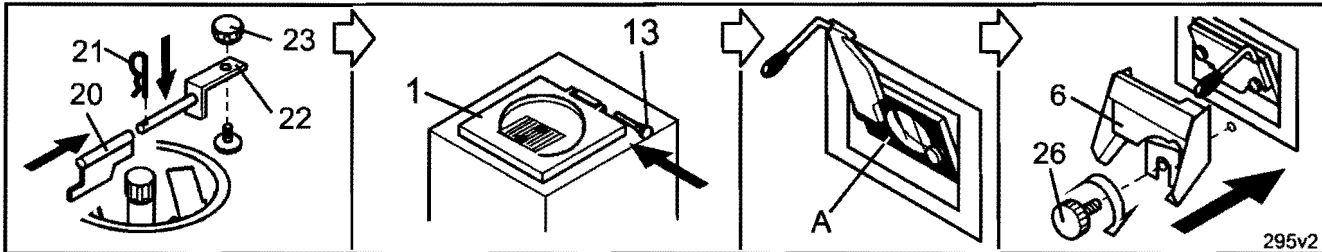

— **Assemble and install the movable blade:**

- place movable blade [20] on its support [22] and clip in safety peg [21];
- put the movable blade section in position and tighten knob [23].

— **Place lid [1] and insert the hinge pins [13].**

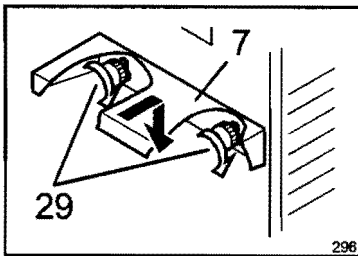

— Slightly, uniformly lubricate the sealing surface [A] with **FOOD-COMPATIBLE LUBRICANT** such as Vaseline. Close lid.



Lubrication is necessary to prevent the door wearing which would lead to **LEAKS** of product during production.

- Place chute [6] and fix knob [26];
- Place basin support [7] and fix knobs [29].

## 10.5 Sanitation

Sanitization is carried out the same way as rinsing but with a warm water and food-machine disinfectant solution. Follow the disinfectant's instructions for its use. If required, rinse with water only.



Following sanitization, close lid and do not touch or wipe with cloths or paper towels any part coming into contact with food.

Check that the water has completely come out of the tub. If necessary, briefly operate beater to let water out completely.

## 11 MAINTENANCE

### 11.1 Standard maintenance (operator)

A correctly operated and thoroughly washed machine requires little and simple maintenance.

How often you will be required to carry out the following operations depends on the machine's conditions and its use.

— **During normal operation:**

- check that set temperatures are reached and easily kept;
- listen for any unusual noise;
- keep machine's outside panels and surroundings clean. Dust, paper or any small objects can enter the machine through the air grills or rest on the air condenser, causing malfunctions or damages.

— When disassembling and washing:



- check machine's parts for wear and tear;
- replace the beater's scrapers as soon as they show signs of wear: the edges are chipped and there are stripes of product on the tub's surface;



**A perfect scraping in the tub means HIGH PERFORMANCE and QUALITY PRODUCT. Replace scrapers regularly (once every THREE MONTHS).**

- after washing, remember to LUBRICATE the sealing surface of the extraction door with FOOD-COMPATIBLE LUBRICANT such as Vaseline;
- regularly remove gaskets from the beater and movable blade's knobs and wash them. Before placing them back, clean their seatings on the knobs. Replace gaskets at least once a year and in case of wear or tear;

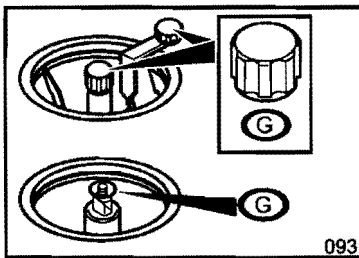

check the integrity of gaskets (indicated with [G] in the figure) and substitute those that are deteriorated.

**Use exclusively original, compatible with food, rubber gaskets.** The spare bag contains a complete series of gaskets approved by the manufacturer.



**To correctly replace the gaskets it is necessary to:**

- remove the old gaskets by using a sharp tool, possibly non-metallic, paying attention not to scratch the seating of the gaskets themselves;
- clean the seatings and the gaskets from any kind of grease before inserting the new gaskets.



**Do NOT lubricate gaskets.**

- always keep a spare parts kit of gaskets and scrapers: to order please refer to Spare Parts Paragraph in the Technical Handbook;
- check power supply cable for damages;
- in case of an air condensing system, DRY remove dust and grime from the condensers' grills (on the back panel). Firstly, vacuum clean and then, if necessary, use a soft brush to remove any remaining dust working FROM THE INSIDE OUT.





**Do NOT use liquid products (dust would become stuck on the condenser) and do NOT push dust INSIDE, to avoid damage to the refrigerating system and dropping of its performance. Air condenser is SUCTION type, therefore dirt accumulates on the outer side and must be removed away from it.**

All inside parts, which the operator must NOT touch, must be checked by Assistance Service (ref. Par. 10.3).

## 11.2 Check of safety devices

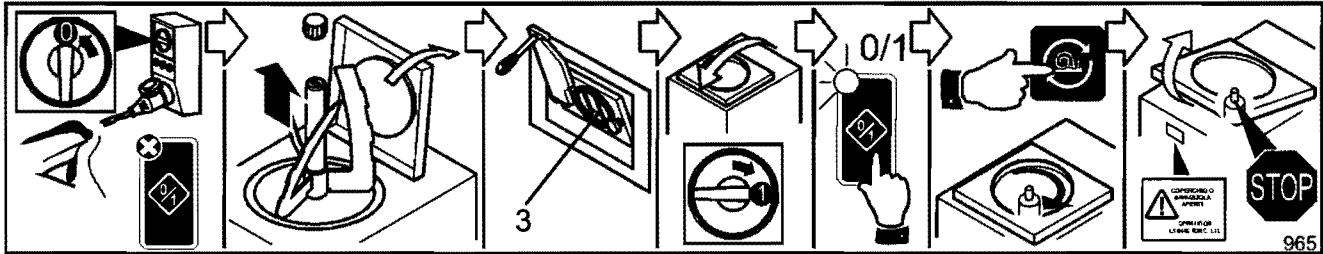
Check proper functioning of all safety devices every three months. Do so by following this procedure:



- if necessary stop the device by pressing the ON/OFF key [0/1]. Rotate the Main Breaker in "0" position. When Main Breaker is correctly working, the POWER's indicator [0/1] must be off.
- open the lid and remove the beater;
- check that protection grill [3] is intact and firmly fixed;
- close the lid and take the Main Breaker in "1" position;
- press the ON/OFF key [0/1] and, afterwards, the SLOW MIXER key  (the beater's shaft will start). Then open the lid. Provided that the lid's magnetic contact is correctly working, the beater's shaft will stop immediately and the Display will show "open lid or extraction chute".
- remove chute with protection flap, close the lid and turn the Beating on again. Provided that the chute's magnetic contact is correctly working, the machine will NOT start and the Display will show "open lid or extraction chute" ;

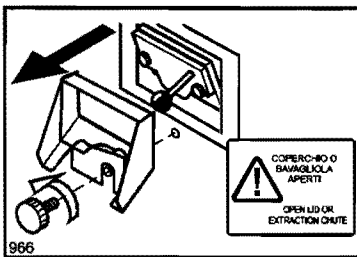

If the machine's functioning is as described, the safety devices are efficient.



**THE MACHINE MUST NOT BE USED IF ONE OR MORE OF THE SAFETY DEVICES SHOULD RESULT DAMAGED OR MALFUNCTIONING!**

## 11.3 Yearly maintenance

Periodically (basing yourself on the environmental conditions in which the device operates) and in any case once every year, make sure to have a general checkup.



**THE CHECK-UP MUST BE MADE BY THE AUTHORISED ASSISTANCE SERVICE, OR, IN ANY CASE, BY TECHNICALLY AUTHORISED PERSONNEL WITH ADEQUATE TOOL. THE MAINTENANCE OPERATIONS RESERVED TO THE SERVICE ASSISTANCE CAN BE DANGEROUS IF CARRIED OUT BY NON-PROFESSIONALS, THEREFORE, FOR HIS OWN SAFETY, THE USER MUST NEVER CARRY THEM OUT.**

## 12 PERIODS OF INACTIVITY

If long periods of inactivity are foreseen, proceed as follows:

- wash up completely the device (see Section 9);
- switch off the power breaker and unplug the device;
- devices with WATER condensation: close the water faucet and relieve pressure from inside the delivery pipe by unscrewing one of the pipe fittings. Remove both delivery and drain pipes and let all water out. Before using the pipes again, following a long period of inactivity, check for any damages or cracks and replace, if necessary, pipe fittings' gaskets.
- if the device will be stored in a different place, group all the documentation, together with the present manual, and enclose it at the device (i.e. in the cylinder).



**Before storing machine (supplied with water condensation) at temperature lower than 0°C it is ABSOLUTELY necessary to release all water from condenser and from feed and drain pipes, failure to do so will cause water to freeze and SERIOUSLY DAMAGE refrigerating system. Call Assistance Service.**

---

## 13 MALFUNCTIONS



**WE RECOMMEND YOU TO CALL IMMEDIATELY THE ASSISTANCE SERVICE IF A MALFUNCTION DIFFERENT FROM THOSE HERE DESCRIBED IS FOUND.**

*Note: the following malfunctions do not refer to problems noticed in the installation phase, but ONLY on correctly installed - and already functioning - devices.*

---

### THE DEVICE DOES NOT WORK OR STOPS WORKING.

---

**With the Main Breaker on 1 the POWER indicator [0/1] DOES NOT TURN ON.**

---

**Cause:** The plug is not correctly plugged.

The plug is defective. A qualified technician should substitute it.

Power in the socket is missing. Check that the breakers, the omnipolar switches and the differentials (lifesavers) on the electric plant are closed. If they aren't, before closing them, make sure that no one is making electrical maintenance.

A protective fuse of the electric plant is blown. Find and eliminate the eventual cause of overload. Substitute blown fuses with others of the same kind.

The supply cable is defective. BEFORE, cut down electrical feeding at the socket by opening the breaker above it, then disconnect the plug and call the Assistance Service.



**DO NOT TOUCH THE DAMAGED ELECTRICAL CABLES BEFORE HAVING CUT DOWN THE ELECTRICAL SUPPLY!**

---

### THE DEVICE CAUSES REPEATED RELEASES OF THE MAINS ELECTRICAL PROTECTIONS OR THE INTERRUPTION OF MAINS FUSES.

---

**Cause:** The capacity of the electrical plant is not sufficient to feed the device.

The electrical characteristics of protections and fuses are not adequate.

Inside breakdown of the device. Call the assistance service.

---

### THE REFRIGERATION IS INSUFFICIENT OR DISACTIVATES IN AN ANOMALOUS WAY.

---

#### AIR CONDENSATION devices

---

**Cause:** Obstacles are placed at the air conditioning's opening, at a distance lower than that described. Restore the minimal distance reported in the Technical Handbook.

The room temperature is too high and condensation is inadequate.

The air condenser is dirty. Request the cleaning at the Assistance Service.

The condenser's fan is broken. Call the Assistance Service.

Break down of the refrigerating system or at the electrical controls. Call the Assistance Service.

---

#### WATER CONDENSATION devices:

---



**Cause:** The flow of condensation water is interrupted or insufficient.

The water tubes present constrictions. Avoid constrictions.

The water condensation faucet/s are partially or totally closed.

The static pressure valve must be newly regulated, otherwise it is broken. Call the Assistance Service.

**Note:** To check if the water correctly flows and if the static pressure valve is regulated, it is sufficient to temporarily detach the water outlet tube (at the end not connected at the device). Water must flow only when the refrigerating plant is in function.

The incoming water's temperature is higher than that prescribed in the Technical Handbook.

**Cause:** The compressor is overheated due to a lack of ventilation. Clean the loopholes and restore the minimal distances for the circulation of air at the sides of the device.

**Note:** it may be necessary to wait up to 30 minutes for the thermal protections to cool down. Break down at the refrigerating plant, or at the electrical controls. Call the Assistance Service.

**ALARMS PAGE**



**Cause:** the lid is not correctly closed or tends to open; the product lifts the lid due to an excessive quantity or an excessive volume increase. Use a smaller amount of mixture or more suitable ingredients.

The lid's magnet is damaged. Call the Assistance Service.

**Cause:** the chute with protection flap is not correctly in place.

The magnet or the chute's magnetic contact is damaged. Please call Assistance Service.



**THE MAGNETS AND THEIR CONTACTS ARE IMPORTANT SAFETY DEVICES!**



**Cause:** the refrigeration system compressor electrical safety device has been activated following a current overload. Switch off the machine, wait a few minutes and retry. If the inconvenience is not eliminated or recurs frequently, contact the Assistance Service.

**Cause:** no power on a phase. Under such conditions the compressor generates an electrical overload on the other phases and this trips the electrical safety device. Cut the power supply to the machine and have fuses and/or system connections checked by a qualified technician.



**WARNING: THE OTHER PHASES COULD BE LIVE.**



**THE MACHINE MOTORS WILL BE DAMAGED IF THEY RUN WITH AN UNPOWERED PHASE.**



**Cause:** the mixer electrical safety device has been activated through over-use or mechanical overload. Check that the product in the vat is not too thick and that there are no other causes of mechanical strain, switch off the machine, wait a few minutes and try again. If the inconvenience is not eliminated or recurs frequently, contact the Assistance Service.

**Note:** in some cases it may be necessary to wait up to 30 minutes for the overload devices to cool down.



**Cause:** the mixer electrical safety device has been activated through over-use or mechanical overload. Check that the product in the vat is not too thick and that there are no other causes of mechanical strain, switch off the machine, wait a few minutes and try again. If the inconvenience is not eliminated or recurs frequently, contact the Assistance Service.

**Note:** in some cases it may be necessary to wait up to 30 minutes for the overload devices to cool down.

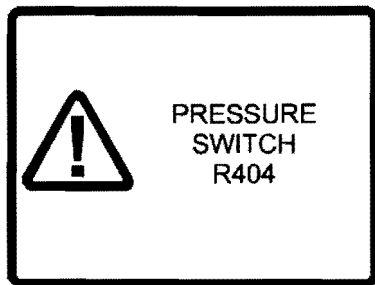

Cause: the refrigeration system safety pressure switch has been activated following excessive strain (REPEATED STARTS TO BE AVOIDED, high pressure, overheating). Switch off the machine, wait a few minutes and restart. If the inconvenience is not eliminated or recurs frequently, contact the Assistance Service.

Cause: Fault in refrigeration or control electronics systems. Contact the Assistance Service.

(see also "Refrigeration insufficient or incorrectly deactivated")

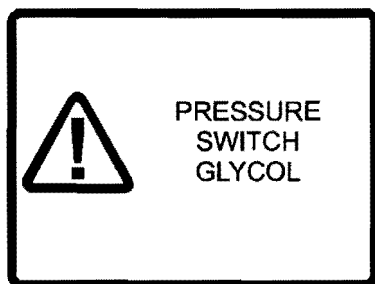

Cause: Fault in glycol system. Contact the Assistance Service.

Cause: Fault on heating elements. Contact the Assistance Service.

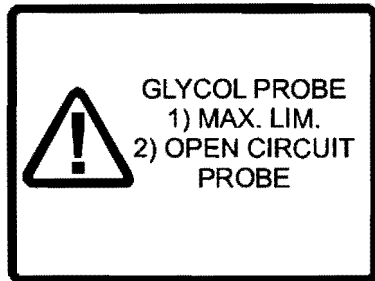

Cause: because of air bubbles in the glycol system the pump is unable to circulate it correctly. Could be caused by a leak or because the machine has been laid on its side or turned upside-down (NEVER DO EITHER). Contact the Assistance Service.

Cause: the glycol system pump is faulty. Contact the Assistance Service.

Cause: the glycol temperature sensor is faulty (disconnected or out of tolerance). Contact the Assistance Service.

Cause: the control circuits are unable to cut the power supply to the glycol system elements (which therefore stay on): the relative control switch is probably jammed. Contact the Assistance Service.

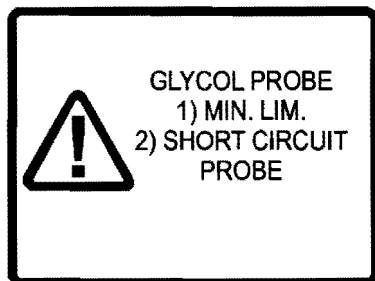

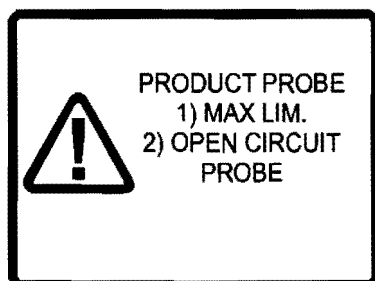

Cause: the control circuits are not able to cut power to the compressor (so it therefore stays on): the relative control switch is probably jammed. Contact the Assistance Service.

Cause: the glycol temperature sensor is faulty (short-circuit) or the relative wiring is damaged. Contact the Assistance Service.



Cause: the machine is running dry or with not enough product. Restore minimum product quantity (at least 1/2 vat).

*Note: if you program a very high HEATING TEMPERATURE it is more probable that the machine will trip this alarm (however, this only happens under certain conditions).*

Cause: the machine has been forgotten in MAINTENANCE  mode with HEATING  and product liquids have completely evaporated (the product is "burning"). Clean and restart a new cycle with fresh product.

Cause: the product temperature sensor is faulty (disconnected or out of tolerance). Contact the Assistance Service.

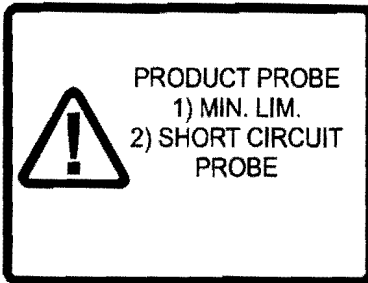

Cause: the product temperature sensor is faulty (short-circuited) or the relative wiring is damaged. Contact the Assistance Service.

Cause: control circuits are unable to cut power to the compressor (which stays on): the relative control switch is probably jammed. Contact the Assistance Service.

## UNUSUAL NOISINESS.

**The noisiness comes, mainly, from the cylinder, when the beating is activated.**

Cause: A layer of ice has developed between the beater and the cylinder: the mixture is not idoneous, or is not sufficient.

The Beater's runners might be damaged or too worn. Check that the runners' scraping edges are not scratched or dented, and that the side runners are not worn as shown in the picture. If they appear worn, replace them.

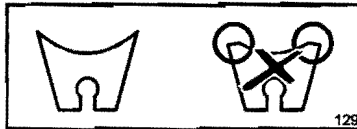

The beater and/or the cylinder are damaged or excessively worn. Call the Assistance Service.

Cause: The tilting blade's fixing knob (where featured) is loosened. Check the state of the gasket(s) (eventually substitute them) and tighten again the fixing knob(s).

The beater and/or the cylinder have gone through a sudden temperature change, and stress mechanically. Stop the device and wait a few minutes.

**The noisiness DOES NOT come from the cylinder, or is also present when the beating is not activated.**

Cause: Inside break down. Call the Assistance Service.